

General Specifications for cover:

Material: High Density Polyethylene (HDPE)
Method of Mfg: Injection Molding
Weight: 1.02 lbs
Cover Height: 2.50"
Min. Wall Thickness: .090" (90 mil)
Bottom OD: 12.690"
Gasket: Neoprene
Qty: 240 per pallet
Standard Color: White, Red186, Blue300
Please inquire about custom colors

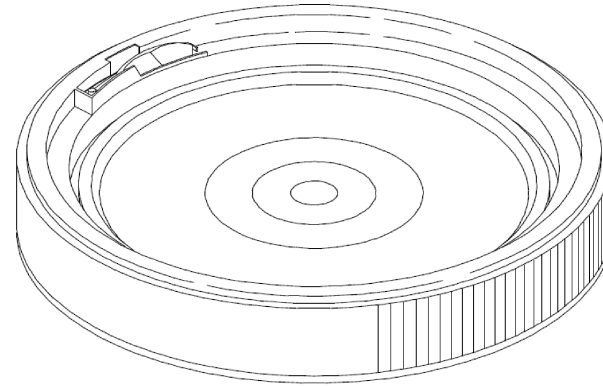

Top ID: 11.25 "

General Specifications for Pail:

Material: High Density Polyethylene (HDPE)
Method of Mfg: Injection Molding
Nominal Capacity: 5.0 Gallons
Weight: 2.40 lbs
Min. Wall Thickness: .090" (90 mil)
Exterior Height: 15.25"
Top ID: 11.25"
Bottom OD: 10.27 "
Shipping: Case: 4 pails and lids per case
Pallet: 120 units
Truckload: 4,320 units
Handle: Plastic Handle
Printing Dimensions: 9.5" x 33"
Heat Transfer Dim: 8.500" x 31.00"
Nesting: Tapered walls for nesting
Standard Color: White
Please inquire about custom colors
UN Certification: 1H2/Y30/S

Height
15.25"

Height
w/cover
16.04"

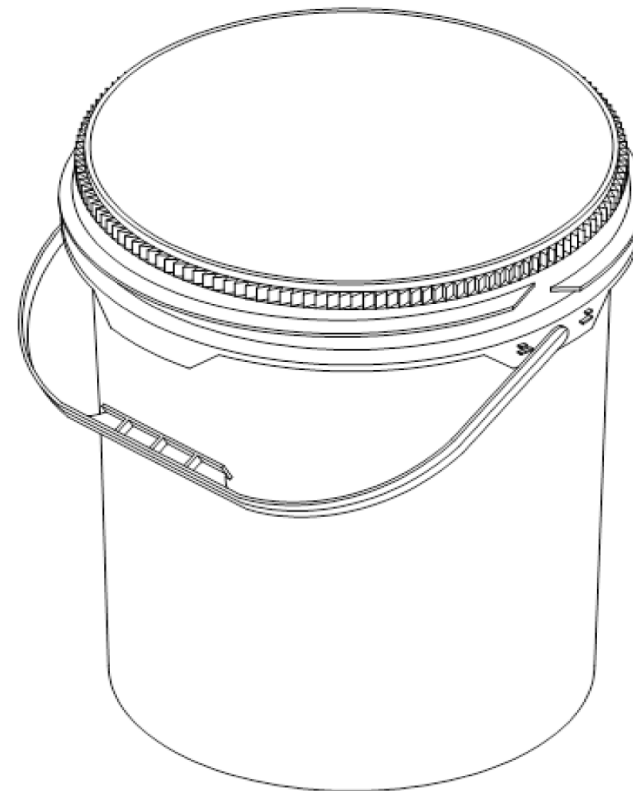

Bottom OD: 10.27"

DISCLAIMER

THIS INFORMATION IS PROVIDED AS A GENERAL GUIDE, INCLUDING DIMENSIONS. IT IS THE CUSTOMER'S RESPONSIBILITIES TO SELECT THE PROPER CONTAINER FOR PRODUCT AND APPLICATION COMPATIBILITY.

DISTRIBUTED BY:



DWG NO.:

DWG10137

DESCRIPTION:

5 Gallon HDPE Screw Top Pail (Regrind)