

General Specifications for cover:

Material: High Density Polyethylene (HDPE)
Method of Mfg: Injection Molding
Weight: 1.02 lbs
Cover Height: 2.50"
Min. Wall Thickness: .090" (90 mil)
Bottom OD: 12.690"
Gasket: Neoprene
Qty: 240 per pallet
Standard Color: White, Red186, Blue300
Please inquire about custom colors

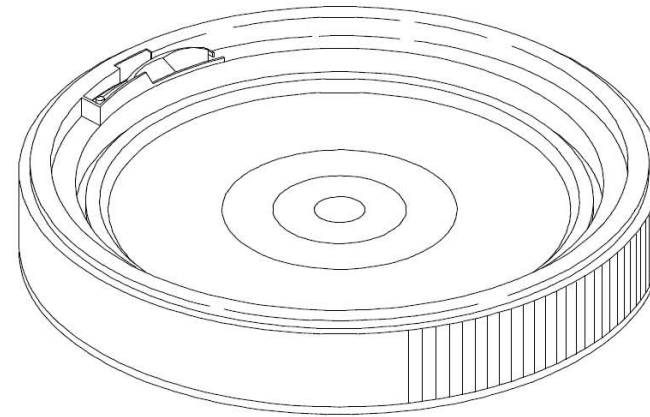

Top ID: 11.25 "

General Specifications for Pail:

Material: High Density Polyethylene (HDPE)
Method of Mfg: Injection Molding
Nominal Capacity: 6.5 Gallons
Weight: 2.85 lbs
Min. Wall Thickness: .090" (90 mil)
Exterior Height: 18.75"
Top ID: 11.25"
Bottom OD: 10.27 "
Shipping Case: 2 pails and lids per case Height
Pallet: 84 units 18.75"
Truckload: 3,360 units
Handle: Plastic Handle
Printing Dimensions: 10.5" x 33" Height
Heat Transfer Dim.: 11.438" x 31.00" w/cover
Nesting: Tapered walls for nesting 19.45"
Standard Color: White
Please inquire about custom colors
UN Certification: 1H2/Y30/S

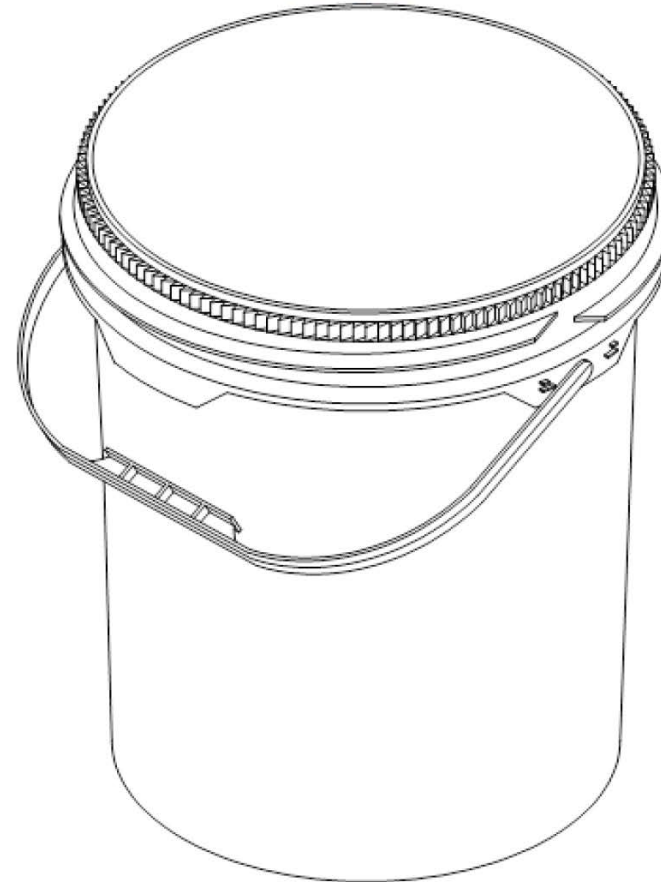

DISCLAIMER

THIS INFORMATION IS PROVIDED AS A GENERAL GUIDE, INCLUDING DIMENSIONS. IT IS THE CUSTOMER'S RESPONSIBILITIES TO SELECT THE PROPER CONTAINER FOR PRODUCT AND APPLICATION COMPATIBILITY.

DISTRIBUTED BY:



REF NO.:

DWG20616

DESCRIPTION:

6.5 gallon Regrind HDPE Screw Top Pail