

1-Gallon EZ Stor® Container with Gasketless Hinged Cover

Multiple Uses

Dry Products
Liquid Products

Product Codes

Container: **ET14**
Description: 1-gallon tall rectangular can

Cover: **E1AH / E1AR / ETDZ**

Description: Gasketless, tamper-evident, hinged,
EZ open & close cover with Ring Pull®

Features

Gauge: 35 mil.
Nominal capacity: 1.0 USG / 3.8 L
Stack performance: 60 lbs. dry products*
Tare weights: Body: .29 lbs. / .13 kgs.
Cover: .07 lbs. / .03 kgs.

Note: *Product designed for use with overpack

Specifications with Cover

Dimensions: 7-7/8"L X 5-7/8"W X 8-3/16"H
Maximum capacity: 1.08 USG / 4.09 L
Tare weight: .36 lbs. / .16 kgs.

Colors

Standard: White, Black, Natural and Clear
Custom: Available at manufacturer's discretion

Decorating Options

Four or six color offset printing*
Pressure sensitive labeling
In-Mold Labeling (IML)

Note: *Where available

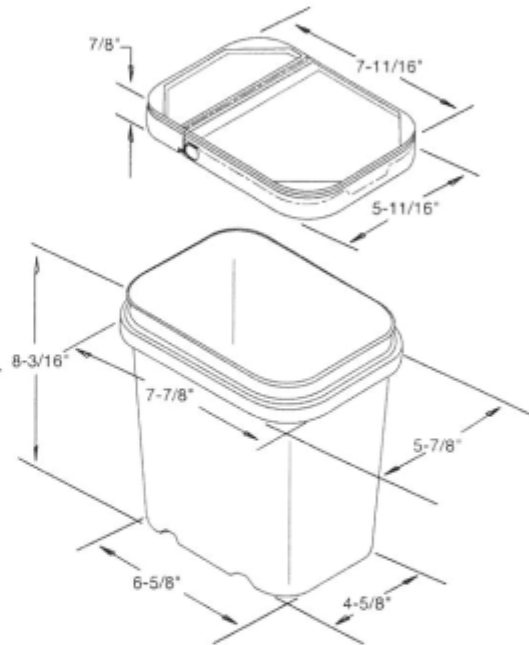

Shipping Data

	Bodies	Covers
Qty. per pallet:	1,000	9,000 (18 boxes of 500)
Gross Weight (lbs./kgs.):*	290/130	630/270
Den. (lbs./C.F./kgs./m3):	5.1/81.3	7.2/108
Length (in./cm.):	50.0/127	50.0/127
Width (in./cm.):	40.0/101.6	40.0/101.6
Height (in./cm.):	49.0/124.5	76.0/193.0

Estimated truckload quantity of 40,000 bodies and covers**

Filled Containers

Product designed for use with overpack

Notes: *Weight does not include pallet / packaging
**Truckload quantity based on 48' trailer

Materials

FDA and HPB approved materials
Resin: Body: Polypropylene (PP)
or Clear Polypropylene (PP)
Cover: Polypropylene (PP)
MSDS Sheets available upon request

Optional Carrying Handle

DISCLAIMER

THIS INFORMATION IS PROVIDED AS A GENERAL GUIDE, INCLUDING DIMENSIONS. IT IS THE CUSTOMER'S RESPONSIBILITIES TO SELECT THE PROPER CONTAINER FOR PRODUCT AND APPLICATION COMPATIBILITY.

DISTRIBUTED BY:



REF NO.:

DWG30555

DESCRIPTION:

White HDPE EZ Stor Cover for 1 Gallon Pails