

Multiple Uses

Dairy Products
Frozen Desserts

Product Codes

Container: **D124**
Description: 3 gallon / 12 quart round can

Cover: **D1D0**

Description: Round snap-on cover

Features

Gauge: 45 mil.
Nominal capacity: 3.0 USG / 11.4L
Stack performance: N/A
Tare weights: Body: .65 lbs. / .30 kgs.
Cover: .15 lbs. / .07 kgs.

Specifications with Cover

Dimensions: 9-3/4"D X 12"H
Maximum capacity: 3.1 USG / 11.7L
Tare weight: .80 lbs. / .37 kgs.

Colors

Standard: White and Natural
Custom: Available at manufacturer's discretion

Decorating Options

Four or six* color offset printing
Print area: 28"W X 8"H
Cover: 6-7/8" Diameter

Note: *Where available

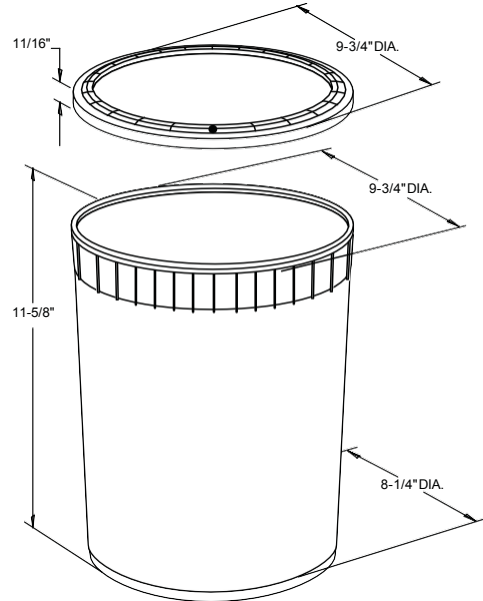

Shipping Data

	Bodies	Covers
Qty. per pallet:	360	3,200 (16 boxes of 200)
Gross Weight (lbs./kgs.):*	234/108	480/224
Den. (lbs./c.f./kgs./m3):	4.2/68.7	4.6/75.2
Length (in./cm.):	49.8/126.5	51/129.5
Width (in./cm.):	39.5/100.3	41/104.1
Height (in./cm.):	48.8/123.9	87/220.9

Filled Containers

80 (20 per layer/4 layers high)
Pallet height: 53"

Estimated truckload quantity of 15,840 bodies and covers**

Notes: *Weight does not include pallet/packaging
**Truckload quantity based on 53' trailer

Materials

FDA approved materials
Resin: Body: High-Density Polyethylene (HDPE)
Cover: Linear Low Density Polyethylene (LLDPE)
MSDS Sheets available upon request

DISTRIBUTED BY:



REF NO.:

DWG30560

DESCRIPTION:

HDPE Dry Seal Cover for 1.5 - 3 Gallon Pails

DISCLAIMER

THIS INFORMATION IS PROVIDED AS A GENERAL GUIDE, INCLUDING DIMENSIONS. IT IS THE CUSTOMER'S RESPONSIBILITIES TO SELECT THE PROPER CONTAINER FOR PRODUCT AND APPLICATION COMPATIBILITY.