

Product Specifications

Tamper-Evident Round EZ Cover® with Ring Pull® (T2WR)

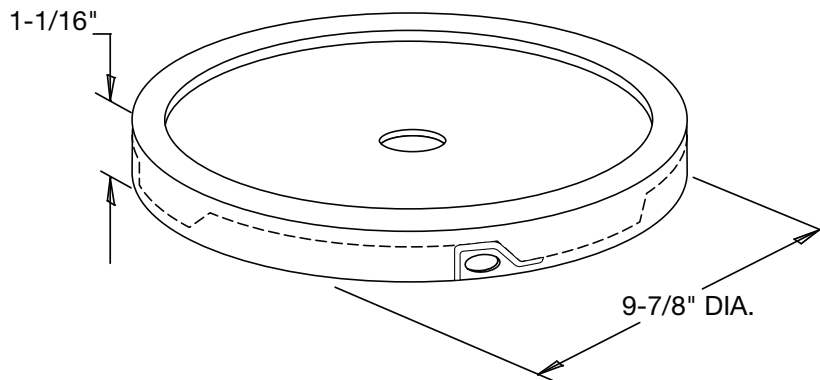

Features

- Exclusive four-tab EZ Cover® design
- EZ to open and reseal
- Tamper-evident tear-strip
- Medium duty cover performance
- Gasketed closure for liquid applications

Used with Ropak 10" Diameter Bodies

<u>Models</u>	<u>Nominal capacity</u>
R027	2-gallon

Product Weight

T2WR: .30 lbs. / .14 kgs.

Shipping Data

Qty. per pallet:	1,920 (24 boxes of 80)
Length (in./cm.):	48/121.9
Width (in./cm.):	41/104.1
Height (in./cm.):	93/236.2

Materials

- Resin: Prime High Density Polyethylene (HDPE)
- Styrene Butadiene Rubber (SBR) Gasket
- FDA and USDA approved materials
- MSDS Sheets available upon request

DISTRIBUTED BY:



REF NO.:

DWG30566

DESCRIPTION:

Black HDPE Tear Tab Cover for 2 Gallon Pails

DISCLAIMER

THIS INFORMATION IS PROVIDED AS A GENERAL GUIDE, INCLUDING DIMENSIONS. IT IS THE CUSTOMER'S RESPONSIBILITIES TO SELECT THE PROPER CONTAINER FOR PRODUCT AND APPLICATION COMPATIBILITY.