

2-Gallon EZ STOR® Container with Hinged Cover

Multiple Uses

Dry Products

Product Codes

Container: **Diamond Pattern**

Description: 2-gallon rectangular can

Cover:

Description: Dry seal, tamper-evident, hinged, EZ open & close cover with Ring Pull®

Features

Gauge: 35+ mil.

Nominal capacity: 2.0 USG / 7.6L

Stack performance: 140 lbs.*

Tare weights: Body: .47 lbs. / .21 kgs.

Cover: .20 lbs. / .09 kgs.

Note: *Ratings will be reduced with uneven load distribution.

Specifications with Cover

Dimensions: 9-3/4"L X 7-3/4"W X 9-5/8"H

Maximum capacity: 2.11 USG / 8 L

Tare weight: .67 lbs. / .30 kgs.

Colors

Standard: White, Natural and Clear

Custom: Available at manufacturer's discretion

Decorating Options

Four or six color offset printing*

Sleeve or pressure sensitive labeling

In-Mold labeling (IML)

Note: *Where available

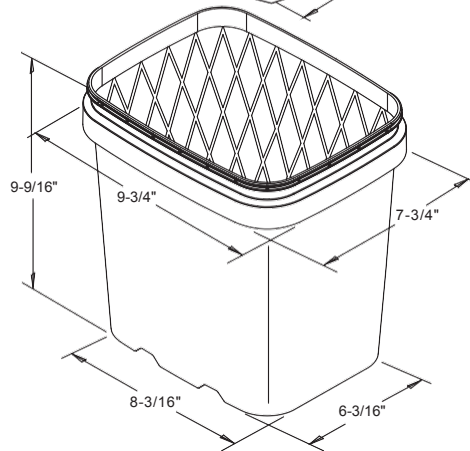
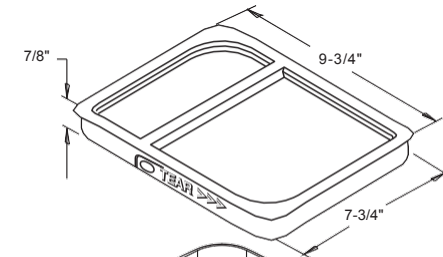

Shipping Data

Qty. per pallet:

Bodies

400

Covers

3,000 (30 boxes of 100)*

Filled Containers

100 (25 per layer / 4 layers high)

Gross Weight (lbs./kgs.)**:

188/84

600/270

Pallet height: 43-1/4"

Den. (lbs./C.F./kgs./m3):

4.7/74.7

8.6/135.9

Length (in./cm.):

49.0/124.5

42/106.7

Width (in./cm.):

40.0/101.6

37/94

Height (in./cm.):

35.0/88.9

78/198.1

Estimated truckload quantity of 17,600 bodies and covers***

Notes: *Bulk pack of 1200 is also available

**Weight does not include pallet / packaging

***Truckload quantity based on 48' trailer

Materials

FDA approved materials

Resin: Body: Polypropylene (PP)

or

Clear Polypropylene

Cover: Polypropylene (PP)

MSDS Sheets available upon request

Optional Carrying Handle

Revision 1/11-1

DISTRIBUTED BY:



REF NO.:

DWG30209

DESCRIPTION:

2 Gallon White HDPE EZ Stor Pail

DISCLAIMER

THIS INFORMATION IS PROVIDED AS A GENERAL GUIDE, INCLUDING DIMENSIONS. IT IS THE CUSTOMER'S RESPONSIBILITIES TO SELECT THE PROPER CONTAINER FOR PRODUCT AND APPLICATION COMPATIBILITY.