

5-Liter EZ STOR® with Gasketless Hinged Cover

Multiple Uses

Dry Products
Liquid Products

Product Codes

Container: **E145**
Description: 5-Liter rectangular can

Cover: **E2AH**

Description: Gasketless, tamper-evident, hinged, EZ open & close cover with Ring Pull®

Features

Gauge: 50 mil.
Nominal capacity: 1.3 USG / 5 L
Stack performance: 125 lbs.*
Tare weights: Body: .46 lbs. / .21 kgs.
Tare weights: Cover: .14 lbs. / .06 kgs.
*Note: *Ratings will be reduced with uneven load distribution.*

Specifications with Cover

Dimensions: 9-13/16" L X 7-11/16" W X 6-7/16" H
Maximum capacity: 1.37 USG / 5.2 L
Tare weight: .60 lbs. / .27 kgs.

Colors

Standard: White, Black, Natural and Clear
Custom: Available at manufacturer's discretion

Decorating Options*

Pressure sensitive labeling
*Note: *See EZ Stor Decoration Summary for further details.*

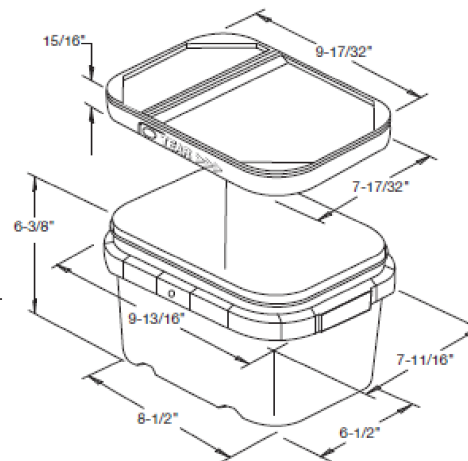

Shipping Data

Shipping Data	Bodies	Covers	Filled Containers
Qty. per pallet:	600	1,200	168 (24 per layer/7 layers high)
Gross Weight (lbs./kgs.):*	276/126	168/72	Pallet height: 48.882"
Den. (lbs./C.F./kgs./m3):	4.9/78	6.6/100.1	
Length (in./cm.):	48/122	48/122	
Width (in./cm.):	40/102	40/102	
Height (in./cm.):	51/130	22.7/57.8	
Estimated truckload quantity of 26,400 bodies and covers**			

*Notes: *Weight does not include pallet / packaging
**Truckload quantity based on 53' trailer*

Materials

FDA and HPB approved materials
Resin: Body: Polypropylene (PP)
or Clear Polypropylene (PP)
Cover: Polypropylene (PP)
MSDS Sheets available upon request

Optional Carrying Handle

DISCLAIMER

THIS INFORMATION IS PROVIDED AS A GENERAL GUIDE, INCLUDING DIMENSIONS. IT IS THE CUSTOMER'S RESPONSIBILITIES TO SELECT THE PROPER CONTAINER FOR PRODUCT AND APPLICATION COMPATIBILITY.

DISTRIBUTED BY:



DWG NO.:

DWG10139

DESCRIPTION:

1.32 gallon HDPE Open Head Pail