

2.5-Gallon Round Container with Snap-on Cover

Multiple Uses

Dairy Products
Frozen Desserts

Product Codes

Container: **D104**
Description: 2.5 gallon / 10 quart round can

Cover: D1D0

Description: Round snap-on cover

Features

Gauge: 45 mil.
Nominal capacity: 2.5 USG / 9.5 L
Stack performance: N/A
Tare weights: Body: .57 lbs. / .26 kgs.
Cover: .15 lbs. / .07 kgs.

Specifications with Cover

Dimensions: 9-3/4"D X 10-1/16"H
Maximum capacity: 2.5 USG / 9.5 L
Tare weight: .72 lbs. / .33 kgs.

Colors

Standard: White and Natural
Custom: Available at manufacturer's discretion

Decorating Options

Four or six" color offset printing
Print area: 28"W X 6-7/8"H
Cover: 6-7/8" Diameter

Note: *Where available

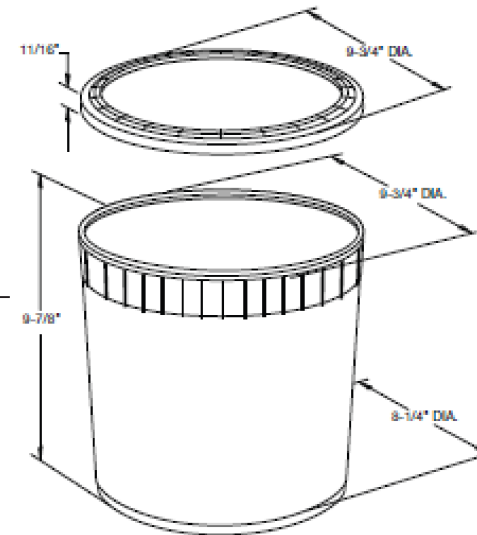

Shipping Data

Qty. per pallet: 380
Gross Weight (lbs./kgs.): 217/99
Den. (lbs./c.f./kgs./m3): 3.8/61.6
Length (in./cm.): 49.8/126.5
Width (in./cm.): 40.3/102.4
Height (in./cm.): 48.8/124
Estimated truckload quantity of 16,720 bodies and covers.**

Bodies

Covers

Filled Containers

3,200 (16 boxes of 200)
480/224
4.6/75.2
51/129.5
41/104.1
87/220.9

80 (20 per layer/4 layers high)
Pallet height: 52.6"

Notes: *Weight does not include pallet/packaging

**Truckload quantity based on 53' trailer

Materials

FDA approved materials
Resin: Body: High-Density Polyethylene (HDPE)
Cover: Linear Low Density Polyethylene (LLDPE)
MSDS Sheets available upon request

DISCLAIMER

THIS INFORMATION IS PROVIDED AS A GENERAL GUIDE, INCLUDING DIMENSIONS. IT IS THE CUSTOMER'S RESPONSIBILITIES TO SELECT THE PROPER CONTAINER FOR PRODUCT AND APPLICATION COMPATIBILITY.

DISTRIBUTED BY:



DWG NO.:

DWG10131

DESCRIPTION:

2.5 gallon HDPE Open Head Pail