

Product Specifications

5.0-Gallon UN Pail with UN Cover

Note: *Rated for Liquids Y1.5/30 and Solids Y43/S for Packing Group II and III (USA and Canada)

Multiple Uses **Product Codes**
 Dry Products Pail: **5500 Series, 55100**
 Liquid Products Description: 5.0-gallon UN Pail

Cover: **2500 Series**
 Description: UN Short Skirt Cover
 Note: *Multiple fitting and venting options available

Features

Gauge: 90 mil
 Nominal capacity: 5.0 USG / 19.0L
 Stack performance: 350 lbs.*
 Tare weights: Body: 2.08 lbs. / 948 gr.
 Cover: .77 lbs. / 350 gr.

Note: *Ratings will be reduced with uneven load distribution.

Specifications with Cover

Dimensions: 12 5/16" D. X 14 11/16" H
 Maximum capacity: 5.3 USG / 21.2 L
 Tare weight: 2.85 lbs. / 1.29 kgs.

Colors

Standard: White, Black and Natural
 Custom: Available at manufacturer's discretion

Decorating Options

Four color offset printing
 Print area: 33"W X 8-1/2"H
 Sleeve or pressure sensitive labeling

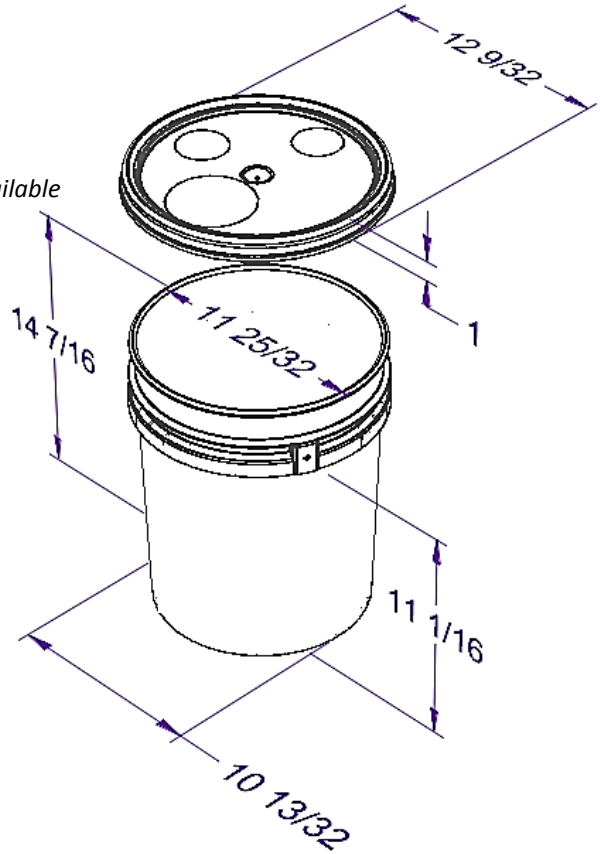

Shipping Data

	Bodies	Covers
Qty. per pallet/carton:	240*	1,200*
Gross Weight (lbs/kgs.)**:	499.2/226	924/419
Length (in./cm.):	48/122	49 1/2"/125.7
Width (in./cm.):	36/91.4	40/101.6
Height (in./cm.):	45/114	97.5/247.6
Approximate truckload quantity of 5,520 pails and covers***		

Filled Containers

36 (12 per layer/3 layers high)
 Pallet height: 47'

Notes:
 *Quantity can vary based on customer request
 **Weight does not include pallet/packaging
 ***Based on 53' trailer and full pallet quantities

Materials

FDA approved materials
 Resin: Body: High-Density Polyethylene (HDPE) Cover: High-Density Polyethylene (HDPE)
 MSDS Sheets available upon request

Optional Carrying Handle – Wire or Plastic

DISTRIBUTED BY: 	REF NO.: DWG30576
DESCRIPTION: 5 Gallon Natural HDPE Open Head Pail with Plastic Handle, UN Rated	

DISCLAIMER

THIS INFORMATION IS PROVIDED AS A GENERAL GUIDE, INCLUDING DIMENSIONS. IT IS THE CUSTOMER'S RESPONSIBILITIES TO SELECT THE PROPER CONTAINER FOR PRODUCT AND APPLICATION COMPATIBILITY.