

# 5.0 Gallon 90 mil LBR Pail with Tear Skirt Cover

## Multiple Uses

UN-solids rated in US to Y27/S  
 UN rated in Canada to Y30/S  
 May also be used for non-hazardous liquids and solids

## Product Codes

Container: **5500 Series, 55100**  
 Description: 5.0 gallon 90 mil Pail  
 Cover: **6500 Series**  
 Description: Standard Tear Skirt Cover  
 Note: \*Multiple fitting and venting options available

## Features

Gauge: 90 mil.  
 Nominal capacity: 5.0 USG / 19.0 L  
 Stack performance: 350 lbs.\*  
 Tare weights: Body: 2.08 lbs. / .948 kgs  
 Cover: .66 lbs. / .300 kgs.

Note: \*Ratings will be reduced with uneven load distribution.

## Specifications with Cover

Dimensions: 12-3/8" D X 14-11/16"H  
 Maximum capacity: 5.3 USG / 20.2 L  
 Tare weight: 2.74 lbs. / 1.25 kgs.

## Colors

Standard: White, Black and Natural  
 Custom: Available at manufacturer's discretion

## Decorating Options

Four color offset printing  
 Print area: 33"W x 8-1/2"H  
 Sleeve or pressure sensitive labeling

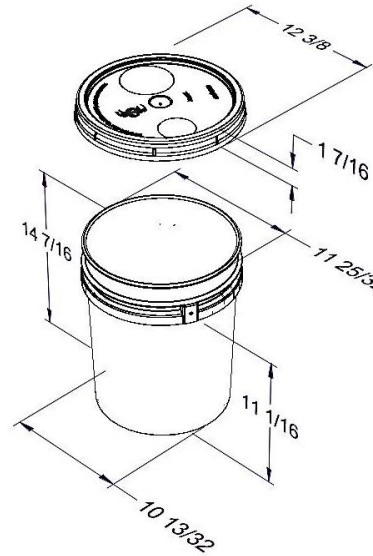

## Shipping Data

Qty. per pallet/carton: 240\*  
 Gross Weight (lbs/kgs.)\*\*: 499 / 26  
 Length (in./cm.): 48 / 122  
 Width (in./cm.): 36 / 91.4  
 Height (in./cm.): 45 / 114

## Bodies

240\*  
 499 / 26  
 48 / 122  
 36 / 91.4  
 45 / 114

## Covers

1,200\*  
 792 / 359  
 50 / 127  
 37.5 / 95.3  
 96 / 243.8

## Filled Containers

36 (12 per layer / 3 layers high)  
 Pallet Height: 47"

Estimated truckload quantity of 5,520 bodies and covers\*\*\*

Notes: \*Quantity can vary based on customer request  
 \*\*Weight does not include pallet/packaging  
 \*\*\*Truckload quantity based on 53' trailer

## Materials

FDA approved materials  
 Resin: Body: High-Density Polyethylene (HDPE)  
 Cover: High-Density Polyethylene (HDPE)

## Optional Carrying Handle

Wire or Plastic

### DISCLAIMER

THIS INFORMATION IS PROVIDED AS A GENERAL GUIDE, INCLUDING DIMENSIONS. IT IS THE CUSTOMER'S RESPONSIBILITIES TO SELECT THE PROPER CONTAINER FOR PRODUCT AND APPLICATION COMPATIBILITY.

DISTRIBUTED BY:



REF NO.:

DWG30154

DESCRIPTION:

5 Gallon White HDPE Open Head Pail