

| PART DATA                           |        |
|-------------------------------------|--------|
| MATERIAL                            | HDPE   |
| WEIGHT (GRAMS)                      | 180.2  |
| VOLUME (CUBIC IN)                   | 252.0  |
| OVERFLOW CAPACITY(OZ)               | 139.6  |
| OVERFLOW CAPACITY(CC)               | 4129.5 |
| MEDIAN PRINT CIRCUMFERENCE          | 20.58  |
| PRINT CIRCUMFERENCE (WITH 3/16 GAP) | 6.551  |
| PRINTING HEIGHT (MAX)               | 5.786  |

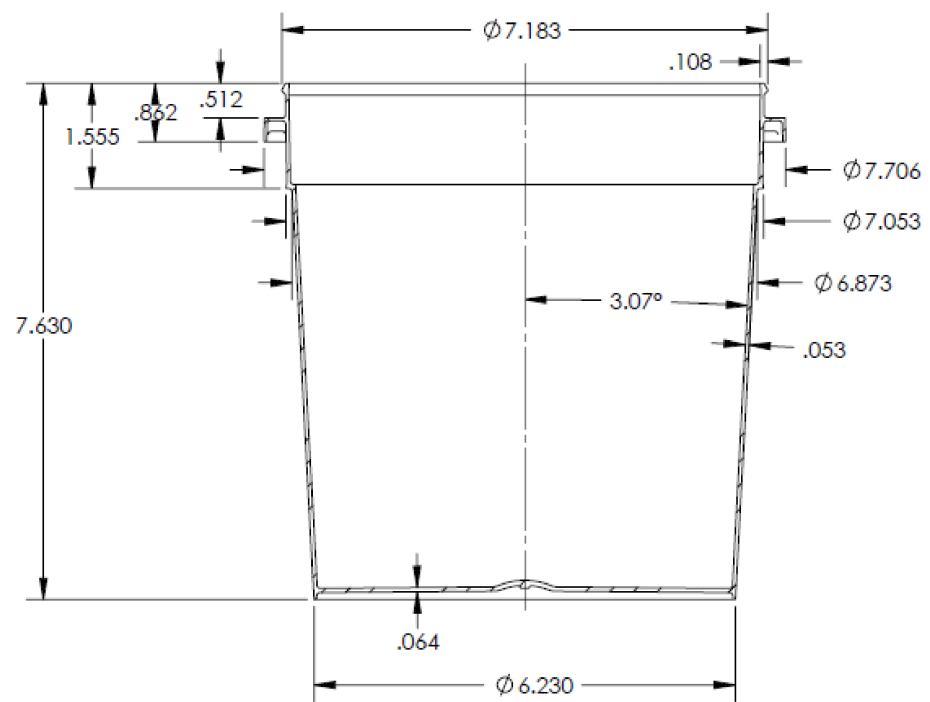

SECTION A-A  
SCALE 1 : 2



**DISCLAIMER**

THIS INFORMATION IS PROVIDED AS A GENERAL GUIDE, INCLUDING DIMENSIONS. IT IS THE CUSTOMER'S RESPONSIBILITIES TO SELECT THE PROPER CONTAINER FOR PRODUCT AND APPLICATION COMPATIBILITY.

DISTRIBUTED BY:



DWG NO.:

DWG10042

DESCRIPTION:

1 gallon HDPE Open Head Pail