

3-Gallon EZ STOR® Container with Hinged Cover

Multiple Uses

Dry Products

Product Codes

Container: **E037**

Description: 3-gallon rectangular can

Cover: **E4DH**

Description: Dry seal, tamper-evident, hinged, EZ open & close cover

Features

Built in hand grips
 Gauge: 65 mil.
 Nominal capacity: 3.0 USG / 11.4 L
 Stack performance: 150 lbs.*
 Tare weights: Body: 1.07 lbs. / .49 kgs.
 Cover: .42 lbs. / .19 kgs.

Note: *Ratings will be reduced with uneven load distribution.

Specifications with Cover

Dimensions: 12"L X 9-15/16"W X 9-3/4"H
 Maximum capacity: 3.25 USG / 12.3 L
 Tare weight: 1.49 lbs. / .68 kgs.

Colors

Standard: White, Black and Natural
 Custom: Available at manufacturer's discretion

Decorating Options*

Four or six color offset printing**
 Sleeve or pressure sensitive labeling
 NXT Graphics®

Note: *See EZ Stor Decoration Summary for further details.

**Where available.

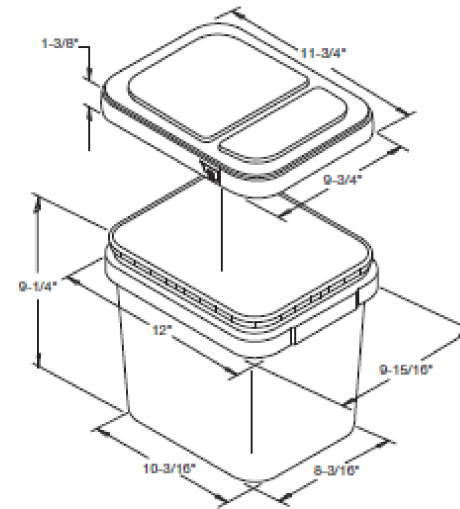

Shipping Data

	Bodies	Covers
Qty. per pallet:	288	2,304 (32 boxes of 72)*
Gross Weight (lbs./kgs.)**:	308/141	967.6/437.7
Den. (lbs./C.F./kgs./m3):	6.5/104.8	11.7/187.3
Length (in./cm.):	48.0/121.9	47/119.4
Width (in./cm.):	40.0/101.6	41/104.1
Height (in./cm.):	42.8/108.6	74/188
Estimated truckload quantity of 12,672 bodies and covers***		

Note: *Bulkpack of 1120 also available

**Weight does not include pallet / packaging

***Truckload quantity based on 53' trailer

Filled Containers

80 (16 per layer / 5 layers high)
 Pallet height: 53"

Materials

FDA approved materials
 Resin: Body: High Density Polyethylene (HDPE)
 Cover: Polypropylene (PP)
 MSDS Sheets available upon request

Optional Carrying Handle

DISCLAIMER

THIS INFORMATION IS PROVIDED AS A GENERAL GUIDE, INCLUDING DIMENSIONS. IT IS THE CUSTOMER'S RESPONSIBILITIES TO SELECT THE PROPER CONTAINER FOR PRODUCT AND APPLICATION COMPATIBILITY.

DISTRIBUTED BY:



DWG NO.:

DWG10150

DESCRIPTION:

3 gallon HDPE EZ Stor Pail