

# 4-Gallon EZ STOR® Container with Hinged Cover

## Multiple Uses

Dry Products

## Product Codes

Container: **E047**

Description: 4-gallon rectangular can

Cover: **E4DH**

Description: Dry seal, tamper-evident, hinged, EZ open & close cover

## Features

Built in hand grips  
 Gauge: 65 mil.  
 Nominal capacity: 4.0 USG / 15.1 L  
 Stack performance: 150 lbs.\*  
 Tare weights: Body: 1.28 lbs. / .58 kgs.  
 Cover: .42 lbs. / .19 kgs.

Note: \*Ratings will be reduced with uneven load distribution.

## Specifications with Cover

Dimensions: 12"L X 9-15/16"W X 12-7/8"H  
 Maximum capacity: 4.25 USG / 16.1 L  
 Tare weight: 1.70 lbs. / .77 kgs.

## Colors

Standard: White, Black and Natural  
 Custom: Available at manufacturer's discretion

## Decorating Options\*

Four or six color offset printing\*\*  
 Sleeve or pressure sensitive labeling  
 NXT Graphics®

Note: \*See EZ Stor Decoration Summary for further details.

\*\*Where available.

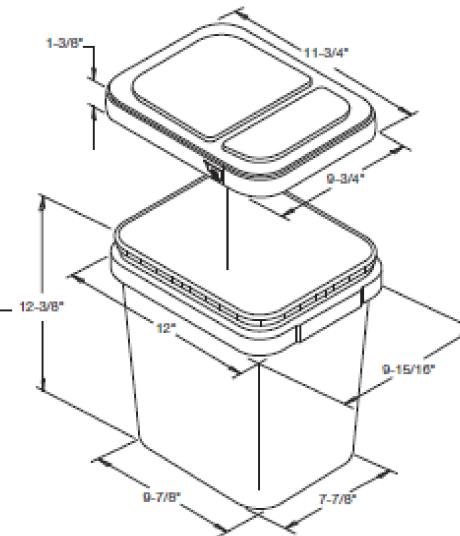

## Shipping Data

	<b>Bodies</b>	<b>Covers</b>
Qty. per pallet:	288	2,304 (32 boxes of 72)
Gross Weight (lbs./kgs.)**:	389/167	976.6/437.7
Den. (lbs./C.F./kgs./m3):	6.5/104.2	11.7/187.3
Length (in./cm.):	48.0/121.9	47/119.4
Width (in./cm.):	40.0/101.6	41/104.1
Height (in./cm.):	51.0/129.5	74/188
Estimated truckload quantity of 12,872 bodies and covers***		

Note: \*Bulkpack of 1120 also available

\*\*Weight does not include pallet / packaging

\*\*\*Truckload quantity based on 53' trailer

## Filled Containers

48 (16 per layer / 3 layers high)  
 Pallet height: 43.5"

## Materials

FDA approved materials  
 Resin: Body: High Density Polyethylene (HDPE)  
 Cover: Polypropylene (PP)  
 MSDS Sheets available upon request

## Optional Carrying Handle

### DISCLAIMER

THIS INFORMATION IS PROVIDED AS A GENERAL GUIDE, INCLUDING DIMENSIONS. IT IS THE CUSTOMER'S RESPONSIBILITIES TO SELECT THE PROPER CONTAINER FOR PRODUCT AND APPLICATION COMPATIBILITY.

DISTRIBUTED BY:



DWG NO.:

DWG10152

DESCRIPTION:

4 gallon HDPE EZ Stor Pail