

3.5 Gallon LBR Pail with Tear Skirt Cover

*Note: Available with UN-Solids Y27/S rating for Packaging Group II and III (USA & Canada)

Multiple Uses **Product Codes**
 Dry Products Pail: **5300 Series**
 Liquid Products Description: 3.5 Gallon LBR Pail

Cover: **6500 Series**
 Description: Standard Tear Skirt Cover
 Note: *Multiple fitting and venting options available

Features

Gauge: 90 mil
 Nominal capacity: 3.5G / 13.2L
 Stack performance: 350 lbs.*
 Tare weights: Body: 1.6 lbs. / 723 gr.
 Cover: .66 lbs. / 300 gr.
 Note: *Ratings will be reduced with uneven load distribution.

Specifications with Cover

Dimensions: 12 3/8"D. X 10 3/4"H
 Maximum capacity: 3.6 USG / 13.6 L
 Tare weight: 2.26 lbs. / 1.03 kgs.

Colors

Standard: White, Black and Natural
 Custom: Available at manufacturer's discretion

Decorating Options

Four color offset printing
 Print area: 33"W X 5-3/4"H
 Sleeve or pressure sensitive labeling

Shipping Data

	Bodies	Covers
Qty. per pallet/carton:	288*	1,200*
Gross Weight (lbs./kgs.)**:	460.8/209	792/359
Length (in./cm.):	50/127	48/121.9
Width (in./cm.):	38.5/97.8	40/101.6
Height (in./cm.):	81/205.7	98/249
Approximate truckload quantity of 6,300 pails and covers***		

Filled Containers

36 (12 per layer/3 layers high)
 Pallet height: 33"

Notes:
 *Quantity can vary based on customer request
 **Weight does not include pallet/packaging
 ***Based on 53' trailer and full pallet quantities

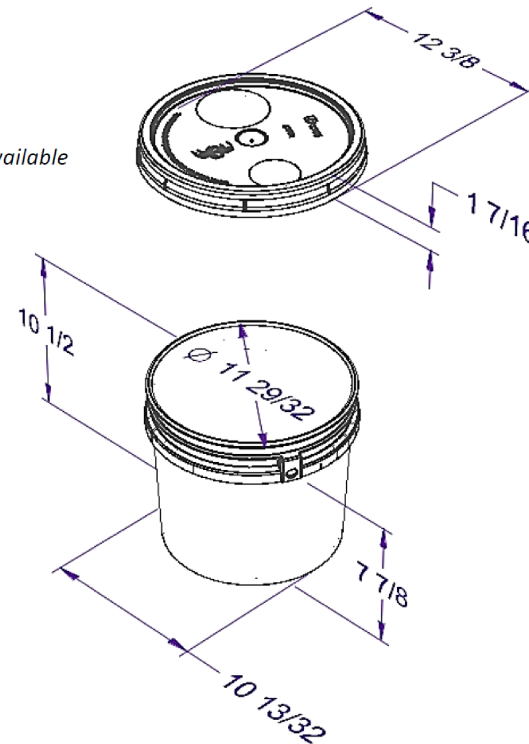

Materials Optional Carrying Handle

FDA approved materials
 Resin: Body: High-Density Polyethylene (HDPE) Cover: High-Density Polyethylene (HDPE)
 MSDS Sheets available upon request

DISCLAIMER THIS INFORMATION IS PROVIDED AS A GENERAL GUIDE, INCLUDING DIMENSIONS. IT IS THE CUSTOMER'S RESPONSIBILITIES TO SELECT THE PROPER CONTAINER FOR PRODUCT AND APPLICATION COMPATIBILITY.	DISTRIBUTED BY: 	DWG NO.: DWG10127
	DESCRIPTION: 3.5 gallon HDPE Open Head Pail	