

5.3-Gallon EZ STOR® Container with Hinged Cover

Multiple Uses

Dry Products

Product Codes

Container: **E538**

Description: 5.3-gallon rectangular can

Cover: **ESDH / ESDR**

Description: Dry seal, tamper-evident, hinged EZ open & close cover

Features

- Built in hand grips
- Gauge: 80 mil.
- Nominal capacity: 5.3 USG / 20 L
- Stack performance: 220 lbs.*
- Tare weights: Body: 1.90 lbs. / .86 kgs.
- Cover: .39 lbs. / .18 kgs.

Note: *Ratings will be reduced with uneven load distribution.

Specifications with Cover

- Dimensions: 11-15/16"L X 9-7/8"W X 14-11/16"H*
- Maximum capacity: 5.6 USG / 21.2 L
- Tare weight: 2.29 lbs. / 1.04 kgs.

Notes: *Based on HDPE body

Colors

- Standard: White, Black, Natural and Clear
- Custom: Available at manufacturer's discretion

Decorating Options*

- Four or six color offset printing**
- Sleeve or pressure sensitive labeling
- In-Mold labeling (IML)
- NXT Graphics®

Note: *See EZ Stor Decoration Summary for further details.

**Where available.

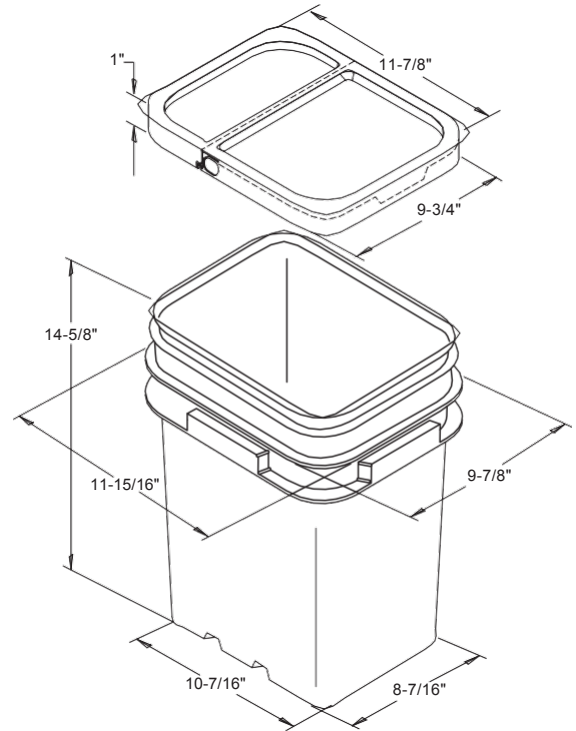

Shipping Data

Qty. per pallet:

Gross Weight (lbs./kgs)*:

Den. (lbs./C.F./kgs./m3):

Length (in./cm.):

Width (in./cm.):

Height (in./cm.):

Bodies

144

273.6/123.8

4.6/72.8

49.5/125.7

41/104.1

50.5/128.3

Covers

1,440 (30 boxes of 48)

561.6/259.2

6.1/99.3

48/121.9

40/101.6

83/210.8

Filled Containers

48 (16 per layer / 3 layer high)

Pallet height: 48.75"

Estimated truckload quantity of 6,336 bodies and covers**

Notes: *Weight does not include pallet / packaging

**Truckload quantity based on 53' trailer

Materials

- FDA approved materials
- Resin: Body: High Density Polyethylene (HDPE)
 or Clear Polypropylene
- Cover: Polypropylene (PP)

MSDS Sheets available upon request

Optional Carrying Handle

DISTRIBUTED BY:



REF NO.:

DWG30577

DESCRIPTION:

5.3 Gallon HDPE EZ Stor Pail

DISCLAIMER

THIS INFORMATION IS PROVIDED AS A GENERAL GUIDE, INCLUDING DIMENSIONS. IT IS THE CUSTOMER'S RESPONSIBILITIES TO SELECT THE PROPER CONTAINER FOR PRODUCT AND APPLICATION COMPATIBILITY.