

## 5.3-Gallon EZ STOR® Container with Hinged Cover

### Multiple Uses

Dry Products

### Product Codes

Container: **E538**

Description: 5.3-gallon rectangular can

Cover: **ESDH / ESDR**

Description: Dry seal, tamper-evident, hinged EZ open & close cover

### Features

Built in hand grips  
 Gauge: 80 mil.  
 Nominal capacity: 5.3 USG / 20 L  
 Stack performance: 220 lbs.\*  
 Tare weights: Body: 1.90 lbs. / .86 kgs.  
 Cover: .39 lbs. / .18 kgs.

Note: \*Ratings will be reduced with uneven load distribution.

### Specifications with Cover

Dimensions: 11-15/16"L X 9-7/8"W X 14-11/16"H\*  
 Maximum capacity: 5.6 USG / 21.2 L  
 Tare weight: 2.29 lbs. / 1.04 kgs.

Notes: \*Based on HDPE body

### Colors

Standard: White, Black, Natural and Clear  
 Custom: Available at manufacturer's discretion

### Decorating Options\*

Four or six color offset printing\*\*  
 Sleeve or pressure sensitive labeling  
 In-Mold labeling (IML)  
 NXT Graphics®

Note: \*See EZ Stor Decoration Summary for further details.

\*\*Where available.

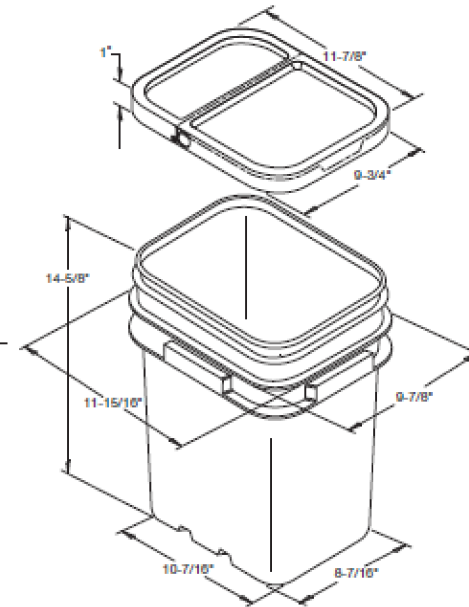

### Shipping Data

|   |             |                        |                                  |
|---|-------------|------------------------|----------------------------------|
| Qty. per pallet:  | 144         | 1,440 (30 boxes of 48) | 48 (16 per layer / 3 layer high) |
| Gross Weight (lbs./kgs)*:                                 | 273.6/123.8 | 561.6/259.2            | Pallet height: 48.75"            |
| Den. (lbs./C.F./kgs./m3):                                 | 4.6/72.8    | 6.1/99.3               |                                  |
| Length (in./cm.):   | 49.5/125.7  | 48/121.9               |                                  |
| Width (in./cm.):  | 41/104.1    | 40/101.6               |                                  |
| Height (in./cm.):   | 50.5/128.3  | 83/210.8               |                                  |
| Estimated truckload quantity of 6,336 bodies and covers** |             |                        |                                  |

### Bodies

### Covers

### Filled Containers

Notes: \*Weight does not include pallet / packaging  
 \*\*Truckload quantity based on 53' trailer

### Materials

FDA approved materials  
 Resin: Body: High Density Polyethylene (HDPE)  
 or Clear Polypropylene  
 Cover: Polypropylene (PP)  
 MSDS Sheets available upon request

### Optional Carrying Handle

### DISCLAIMER

THIS INFORMATION IS PROVIDED AS A GENERAL GUIDE, INCLUDING DIMENSIONS. IT IS THE CUSTOMER'S RESPONSIBILITIES TO SELECT THE PROPER CONTAINER FOR PRODUCT AND APPLICATION COMPATIBILITY.

DISTRIBUTED BY:



DWG NO.:

DWG10153

DESCRIPTION:

5.3 gallon HDPE EZ Stor Pail