

Specifications	IN/LB	MM/KG
Bumper Ring Diameter (D1)	12.3	313
Satellite Ring Diameter (D2)	12.1	307
Curl Diameter (D3)	11.9	303
Base Diameter (D4)	10.3	262
Pail Height (H1)	14.6	371
Bumper Ring (H2)	11.2	285
Pail Weight	2.05	0.93
Overall Package Diameter (D)	12.3	313
Overall Package Height (H)	14.8	376
Overall Package Weight	2.8	1.27
Shipping Information		
Pails per pallet	264	
Covers per pallet	1248	
Pails/Covers per truckload	6600	

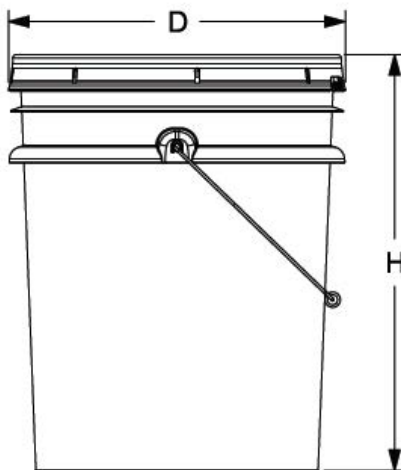
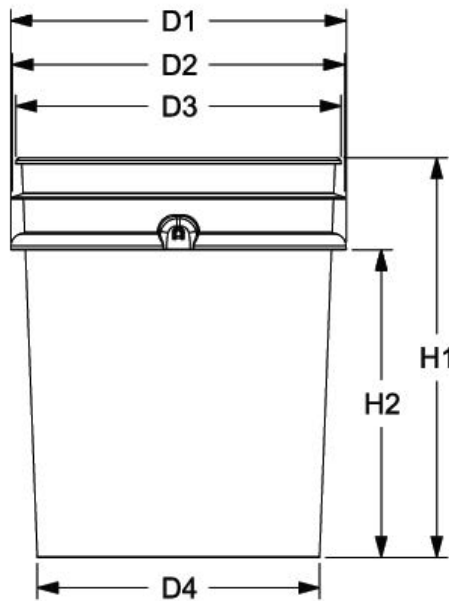

Features & Benefits

- Gauge: 90 mil
- Nominal volume: 5 USG/18.9L
- Material: High-Density Polyethylene (HDPE)
- Maximum capacity: 5.5USG
- Colors: Standard: White, Black, and Natural (Custom colors available upon request)
- Decorating Options: 1 - 6 color offset printing
Heat transfer labels, sleeve or pressure sensitive labeling.
- Print area:
Max Height = 8.5"
Max Length = 33.50"
- Handles Options: 12 ga. Galvanized Steel with HDPE grip, HDPE plastic
- National Motor Freight (NMF) Certification
- Fitting Options: Blank, Tint, Buna

DISCLAIMER

THIS INFORMATION IS PROVIDED AS A GENERAL GUIDE, INCLUDING DIMENSIONS. IT IS THE CUSTOMER'S RESPONSIBILITIES TO SELECT THE PROPER CONTAINER FOR PRODUCT AND APPLICATION COMPATIBILITY.

DISTRIBUTED BY:



REF NO.:

DWG20629

DESCRIPTION:

5 gallon HDPE Open Head Pail