

# Product Specifications

## 5.0-Gallon 90 mil LBR Pail with Standard Tear Skirt Cover

*\*Note: Available with UN-Solids Y27/S rating for Packaging Group II and III (USA & Canada)*

### Multiple Uses

Dry Products  
Liquid Products

### Product Codes

Pail: 5500 Series, 55100  
Description: 5.0-gallon LBR Pail  
  
Cover: 6500 Series  
Description: Tear Skirt Cover, Standard  
*Note: \*Multiple fitting and venting options available*

### Features

Gauge: 90 mil  
Nominal capacity: 5.0 USG / 19.0 L  
Stack performance: 350 lbs.\*  
Tare weights: Body: 2.08 lbs. / 948 gr.  
Cover: .66 lbs. / 300 gr.  
*Note: \*Ratings will be reduced with uneven load distribution.*

### Specifications with Cover

Dimensions: 12 3/8" D. X 14 11/16" H  
Maximum capacity: 5.3 USG / 21.2L  
Tare weight: 2.74 lbs. / 1.25 kgs.

### Colors

Standard: White, Black and Natural  
Custom: Available at manufacturer's discretion

### Decorating Options

Four color offset printing  
Print area: 33"W X 8-1/2"H  
Sleeve or pressure sensitive labeling

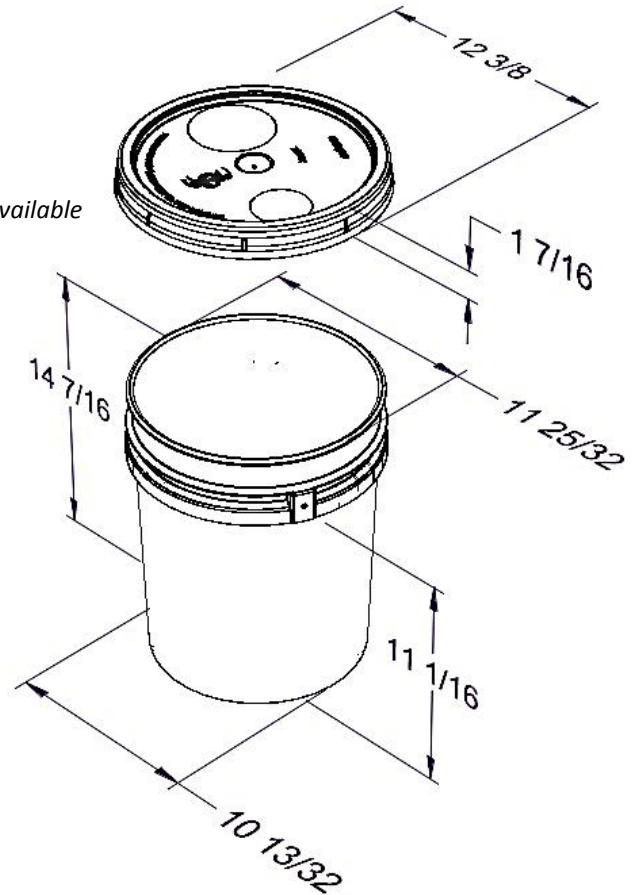

### Shipping Data

	Bodies	Covers
Qty. per pallet/carton:	240*	1,200*
Gross Weight (lbs/kgs.)**:	499.2/226	792/359
Length (in./cm.):	48/122	50/127
Width (in./cm.):	36/91.4	37.5/95.3
Height (in./cm.):	45/114	96/243.8

Approximate truckload quantity of 5,520 pails and covers\*\*\*

### Filled Containers

36 (12 per layer/3 layers high)  
Pallet height: 47'

### Notes:

- \*Quantity can vary based on customer request
- \*\*Weight does not include pallet/packaging
- \*\*\*Based on 53' trailer and full pallet quantities

### Materials

FDA approved materials  
Resin: Body: High-Density Polyethylene (HDPE) Cover: High-Density Polyethylene (HDPE)  
MSDS Sheets available upon request

**Optional Carrying Handle** – Wire or Plastic

DISTRIBUTED BY:



REF NO.:

DWG30915

DESCRIPTION:

5 Gallon Plastic HDPE OH Pail

### DISCLAIMER

THIS INFORMATION IS PROVIDED AS A GENERAL GUIDE, INCLUDING DIMENSIONS. IT IS THE CUSTOMER'S RESPONSIBILITIES TO SELECT THE PROPER CONTAINER FOR PRODUCT AND APPLICATION COMPATIBILITY.