

5.0 Gallon 90 mil LBR Pail with Long Skirt Cover

Multiple Uses

Dry Products
Liquid Products

Product Codes

Container: **5500 Series, 55100**
Description: 5 gallon Low Beam Ring Pail

Cover: 4500 Series

Description: Standard Long Skirt Cover
Note: *Multiple fitting and venting options available

Features

Gauge: 90 mil.
Nominal capacity: 5.0 USG / 19.0 L
Stack performance: 350 lbs.*
Tare weights: Body: 2.08 lbs. / .948 kgs
Cover: .66 lbs. / .300 kgs.

Note: *Ratings will be reduced with uneven load distribution.

Specifications with Cover

Dimensions: 12-1/32" D X 14-11/16"H
Maximum capacity: 5.3 USG / 20.2 L
Tare weight: 2.74 lbs. / 1.25 kgs.

Colors

Standard: White, Black and Natural
Custom: Available at manufacturer's discretion

Decorating Options

Four color offset printing
Print area: 33"W x 8-1/2"H
Sleeve or pressure sensitive labeling

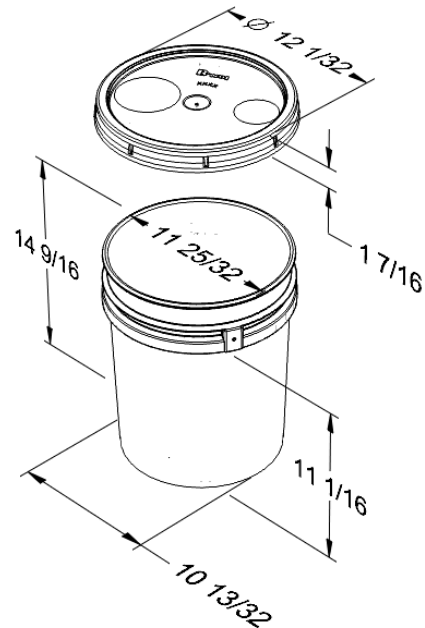

Shipping Data

Qty. per pallet/carton:
Gross Weight (lbs/kgs.)**:
Length (in./cm.):
Width (in./cm.):
Height (in./cm.):

Bodies

240*
499 / 226
48 / 122
36 / 91.4
45 / 114

Covers

1,200*
792 / 359
50 / 127
37.5 / 95.3
96 / 243.8

Filled Containers

36 (12 per layer / 3 layers high)
Pallet Height: 47"

Estimated truckload quantity of 5,520 bodies and covers***

Notes: *Quantity can vary based on customer request
**Weight does not include pallet/packaging
***Truckload quantity based on 53' trailer

Materials

FDA approved materials
Resin: Body: High-Density Polyethylene (HDPE)
Cover: High-Density Polyethylene (HDPE)

Optional Carrying Handle

Wire or Plastic

DISTRIBUTED BY:



REF NO.:

DWG31117

DESCRIPTION:

5 Gallon Black HDPE Open Head Pail w/ Plastic Handle

DISCLAIMER

THIS INFORMATION IS PROVIDED AS A GENERAL GUIDE, INCLUDING DIMENSIONS. IT IS THE CUSTOMER'S RESPONSIBILITIES TO SELECT THE PROPER CONTAINER FOR PRODUCT AND APPLICATION COMPATIBILITY.