

## 5.0-Gallon UN Pail with UN Cover

Note: \*Rated for Liquids Y1.5/30 and Solids Y43/S for Packing Group II and III (USA and Canada)

### Multiple Uses

Dry Products

Liquid Products

### Product Codes

Pail: 5500 Series, 55100

Description: 5.0-gallon UN Pail

### Cover: 2500 Series

Description: UN Short Skirt Cover

Note: \*Multiple fitting and venting options available

### Features

Gauge: 90 mil

Nominal capacity: 5.0 USG / 19.0L

Stack performance: 350 lbs.\*

Tare weights: Body: 2.08 lbs. / 948 gr.

Cover: .77 lbs. / 350 gr.

Note: \*Ratings will be reduced with uneven load distribution.

### Specifications with Cover

Dimensions: 12 5/16"D. X 14 11/16"H

Maximum capacity: 5.3 USG / 21.2 L

Tare weight: 2.85 lbs. / 1.29 kgs.

### Colors

Standard: White, Black and Natural

Custom: Available at manufacturer's discretion

### Decorating Options

Four color offset printing

Print area: 33"W X 8-1/2"H

Sleeve or pressure sensitive labeling

### Shipping Data

Qty. per pallet/carton:

Gross Weight (lbs./kgs.)\*\*:

Length (in./cm.):

Width (in./cm.):

Height (in./cm.):

Approximate truckload quantity of 5,520 pails and covers\*\*\*

### Bodies

240\*

499.2/226

48/122

36/91.4

45/114

### Covers

1,200\*

924/419

49 1/2"/125.7

40/101.6

97.5/247.6

### Filled Containers

36 (12 per layer/3 layers high)

Pallet height: 47"

### Notes:

\*Quantity can vary based on customer request

\*\*Weight does not include pallet/packaging

\*\*\*Based on 53' trailer and full pallet quantities

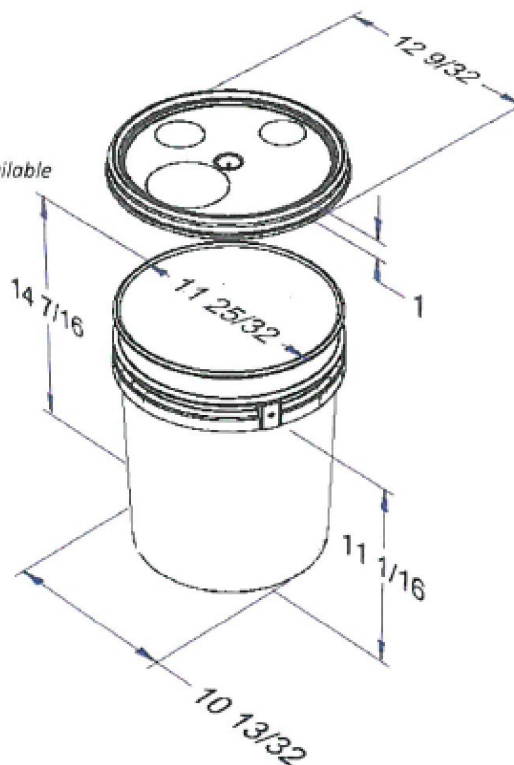

### Materials

FDA approved materials

Resin: Body: High-Density Polyethylene (HDPE) Cover: High-Density Polyethylene (HDPE)

MSDS Sheets available upon request

Optional Carrying Handle – Wire or Plastic

### DISCLAIMER

THIS INFORMATION IS PROVIDED AS A GENERAL GUIDE, INCLUDING DIMENSIONS. IT IS THE CUSTOMER'S RESPONSIBILITIES TO SELECT THE PROPER CONTAINER FOR PRODUCT AND APPLICATION COMPATIBILITY.

DISTRIBUTED BY:



DWG NO.:

DWG10136

DESCRIPTION:

5 gallon HDPE Open Head Pail