

6.5-Gallon EZ Stor® Container with Hinged Cover

Multiple Uses

Dry Products

Product Codes

Container: **E659**

Description: 6.5-gallon rectangular can

Cover: **E6DH**

Description: Dry seal, tamper-evident, hinged EZ open & close cover with Ring Pull®

Features

Built-in hand grips
 Gauge: 90 mil.
 Nominal capacity: 6.5 USG / 24.6 L
 Stack performance: 300 lbs.*
 Tare weights: Body: 2.27 lbs. / 1.03 kgs.
 Cover: .50 lbs. / .23 kgs.

Note: *Ratings will be reduced with uneven load distribution.

Specifications with Cover

Dimensions: 13-3/8"L X 12"W X 13-13/16"H
 Maximum capacity: 6.74 USG / 25.5 L
 Tare weight: 2.77 lbs. / 1.26 kgs.

Colors

Standard: White, Black and Natural
 Custom: Available at manufacturer's discretion

Decorating Options*

Four or six color offset printing**
 Sleeve or pressure sensitive labeling
 NXT Graphics®

Note: *See EZ Stor Decoration Summary for further details.

**Where available.

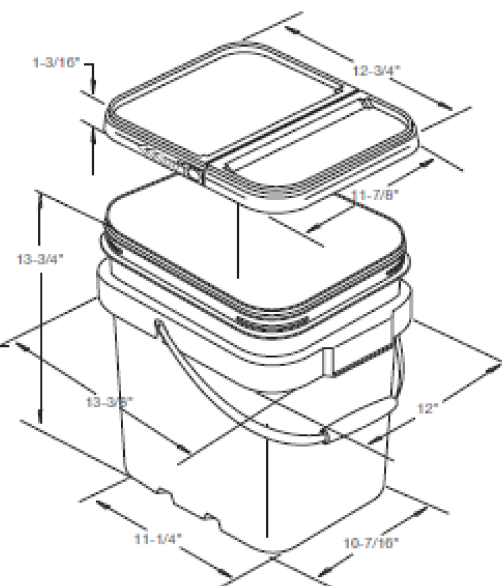

Shipping Data

	Bodies	Covers	Filled Containers
Qty. per pallet/carton:	120	600	36 (12 per layer/3 layers high)
Gross Weight (lbs./kgs.):	272.4/123.6	300/138	Pallet height: 45.9"
Den. (lbs./C.F./kgs./m3):	5.1/81.8	9.0/146.2	
Length (in./cm.):	48/121.9	48/121.9	
Width (in./cm.):	40/101.6	40/101.6	
Height (in./cm.):	48/121.9	30/76.2	
Estimated truckload quantity of 5,760 bodies and covers**			

Notes: *Weight does not include pallet / packaging

**Truckload quantity based on 53' trailer

Materials

FDA approved materials
 Resin: Body: High-Density Polyethylene (HDPE)
 Cover: Polypropylene (PP)
 MSDS Sheets available upon request

Optional Carrying Handle

DISCLAIMER

THIS INFORMATION IS PROVIDED AS A GENERAL GUIDE, INCLUDING DIMENSIONS. IT IS THE CUSTOMER'S RESPONSIBILITIES TO SELECT THE PROPER CONTAINER FOR PRODUCT AND APPLICATION COMPATIBILITY.

DISTRIBUTED BY:



DWG NO.:

DWG10156

DESCRIPTION:

6.5 gallon HDPE EZ Stor Pail