

8-Gallon EZ STOR® Container with Hinged Cover

Multiple Uses

Dry Products

Product Codes

Container: **E088**

Description: 8-gallon rectangular can

Cover: **E8DH**

Description: Dry seal, tamper-evident, hinged, EZ open & close cover with Ring Pull®

Features

Built in hand grips
 Gauge: 80 mil.
 Nominal capacity: 8 USG / 30.3 L
 Stack performance: 200 lbs.*
 Tare weights: Body: 2.87 lbs. / 1.3 kgs.
 Cover: .66 lbs. / .3 kgs.

Note: *Ratings will be reduced with uneven load distribution.

Specifications with Cover

Dimensions: 16-1/4"L X 13-1/4"W X 12-3/4"H
 Maximum capacity: 8.8 USG / 33.3 L
 Tare weight 3.53 lbs. / 1.6 kgs.

Colors

Standard: White, Black and Natural
 Custom: Available at manufacturer's discretion

Decorating Options*

Silk-Screen**
 Sleeve or pressure sensitive labeling
 Logo Emboss for Cover: 7-3/4"W X 4"H

Note: *See EZ Stor Decoration Summary for further details.

**Where available.

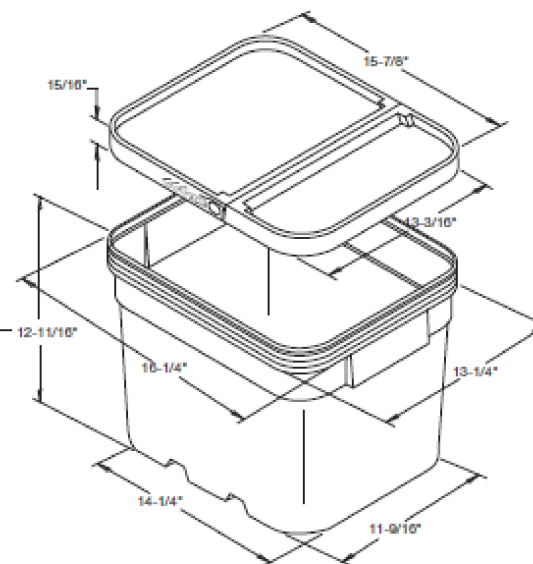

Shipping Data

Qty. per pallet:

Bodies

81

Covers

1,215 (45 boxes of 27)*

Filled Containers

27 (9 per layer / 3 layers high)

Gross Weight (lbs./kgs.)**:

232.5/105.3

801.9/364.5

Pallet height: 42.75"

Den. (lbs./C.F./kgs./m3):

4.0/65.8

7.2/115.7

Length (in./cm.):

49.5/125.7

51.0/129.5

Width (in./cm.):

42/106.7

42.0/106.7

Height (in./cm.):

48/121.9

90.0/228.6

Estimated truckload quantity of 3,888 bodies and covers***

Notes: * Bulk pack of 486 is also available

** Weight does not include pallet / packaging

*** Truckload quantity based on 53' trailer

Materials

FDA approved materials
 Resin: Body: High Density Polyethylene (HDPE)
 Cover: Polypropylene (PP)
 MSDS Sheets available upon request

DISCLAIMER

THIS INFORMATION IS PROVIDED AS A GENERAL GUIDE, INCLUDING DIMENSIONS. IT IS THE CUSTOMER'S RESPONSIBILITIES TO SELECT THE PROPER CONTAINER FOR PRODUCT AND APPLICATION COMPATIBILITY.

DISTRIBUTED BY:



REF NO.:

DWG10154

DESCRIPTION:

8 gallon HDPE EZ Stor Pail