

6.0 Gallon Screw Top ST3 Pail with Cover

Note: *UN Solids rated to Y27.0/S

Multiple Uses

Dry Products

Product Codes

Pail: 9900 Series

Description: 6.0 Gallon Screw Top Pail

Cover: 8900 Series

Description: 3.5G - 6.0 Gallon Screw Top Cover

Features

Pail Gauge: 100 mil, Cover Gauge: 90mil

Nominal capacity: 6.0 USG / 22.7 L

Stack performance: 350 lbs.*

Tare weights: Body: 2.91 lbs. / 1,320 gr.

Cover: .73 lbs. / 332 gr.

Note: *Ratings will be reduced with uneven load distribution.

Specifications with Cover

Dimensions: 12 5/8" D. X 14 3/4" H

Maximum capacity: 6.3 USG / 23.8 L

Tare weight: 3.64 lbs. / 1.65 kgs.

Colors

Standard: White, Black and Natural

Custom: Available at manufacturer's discretion

Decorating Options

Four color offset printing

Print area: 33"W X 8-1/2"H

Sleeve or pressure sensitive labeling

Shipping Data

	Bodies	Covers
Qty. per pallet/carton:	144*	1,152*
Gross Weight (lbs./kgs.)**:	419/923.7	420.5/190.7
Length (in./cm.):	48/121.9	50.25/127.7
Width (in./cm.):	36/91.4	37.7/95.7
Height (in./cm.):	75.6/192	108/274.3
Approximate truckload quantity of 3,456 pails and covers***		

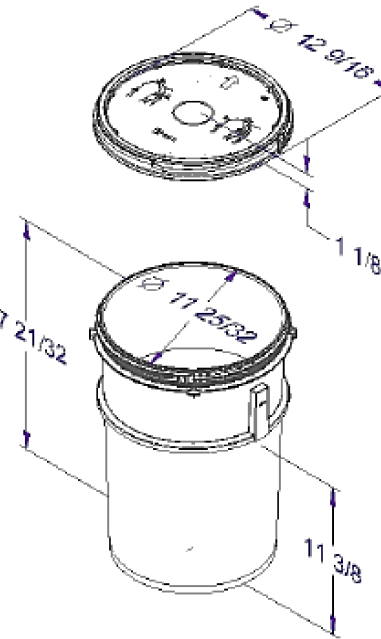

Filled Containers

36 (12 per layer/3 layers high)

Pallet height: 53.25"

Notes:

*Quantity can vary based on customer request

**Weight does not include pallet/packaging

***Based on 53' trailer and full pallet quantities

Materials

FDA approved materials

Resin: Body: High-Density Polyethylene (HDPE)

Cover: High-Density Polyethylene (HDPE)

MSDS Sheets available upon request

Carrying Handle – Plastic

DISCLAIMER

THIS INFORMATION IS PROVIDED AS A GENERAL GUIDE, INCLUDING DIMENSIONS. IT IS THE CUSTOMER'S RESPONSIBILITIES TO SELECT THE PROPER CONTAINER FOR PRODUCT AND APPLICATION COMPATIBILITY.

DISTRIBUTED BY:



DWG NO.:

DWG10169

DESCRIPTION:

6 gallon HDPE Open Head Pail