

# 7.0 Gallon 100mil LBR Pail with Tear Skirt Cover

*\*Note: Available with UN-Solids Y27/S rating*

## Multiple Uses

Dry Products  
Liquid Products

## Product Codes

Container: **5700 Series**  
Description: 7 gallon LBR Standard Pail

## Cover: 6500 Series

Description: Standard Tear Skirt Cover

*Note: \*Multiple fitting and venting options available*

## Features

Gauge: 100 mil.  
Nominal capacity: 7.0 USG / 26.5 L  
Stack performance: 350 lbs.\*  
Tare weights: Body: 2.97 lbs. / 1.350 kgs  
Cover: .66 lbs. / .300 kgs.

*Note: \*Ratings will be reduced with uneven load distribution.*

## Specifications with Cover

Dimensions: 12-3/8" D X 20"H  
Maximum capacity: 7.4 USG / 28 L  
Tare weight: 3.63 lbs. / 1.65 kgs.

## Colors

Standard: White, Black and Natural  
Custom: Available at manufacturer's discretion

## Decorating Options

Four color offset printing  
Print area: 33"W x 10-1/4"H  
Sleeve or pressure sensitive labeling

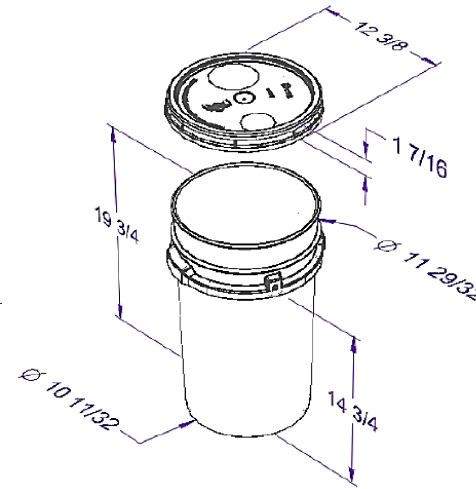

## Shipping Data

Qty. per pallet/carton:  
Gross Weight (lbs/kgs.)\*\*:  
Length (in./cm.):  
Width (in./cm.):  
Height (in./cm.):

## Bodies

168\*  
499 / 226  
50 / 127  
38.5 / 98  
99.4 / 252

## Covers

1,200\*  
792 / 359  
48 / 122  
40 / 102  
98 / 249

## Filled Containers

36 (12 per layer / 3 layers high)  
Pallet Height: 60"

Estimated truckload quantity of 3,864 bodies and covers\*\*\*

*Notes: \*Quantity can vary based on customer request*

*\*\*Weight does not include pallet/packaging*

*\*\*\*Truckload quantity based on 53' trailer*

## Materials

FDA approved materials  
Resin: Body: High-Density Polyethylene (HDPE)  
Cover: High-Density Polyethylene (HDPE)

## Optional Carrying Handle

Wire or Plastic

MSDS Sheets available upon request

## DISCLAIMER

THIS INFORMATION IS PROVIDED AS A GENERAL GUIDE, INCLUDING DIMENSIONS. IT IS THE CUSTOMER'S RESPONSIBILITIES TO SELECT THE PROPER CONTAINER FOR PRODUCT AND APPLICATION COMPATIBILITY.

DISTRIBUTED BY:



DWG NO.:

DWG10125

DESCRIPTION:

7 gallon HDPE Open Head Pail