

10.7 Gallon Screw Top ST3 Pail with Cover

Note: *UN Solids rated to Y54.0/5

Multiple Uses

Dry Products

Product Codes

Pail: 9900 Series

Description: 10.7 Gallon Screw Top Pail

Cover: 8900 Series

Description: 7.7 / 10.7 Gallon Screw Top Cover

Features

Gauge: 100 mil

Nominal capacity: 10.7 USG / 40.5 L

Stack performance: 350 lbs.*

Tare weights: Body: 5.5 lbs. / 2,494 gr.

Cover: 1.32 lbs. / 600 gr.

Note: *Ratings will be reduced with uneven load distribution.

Specifications with Cover

Dimensions: 15 1/2" D. X 21" H

Maximum capacity: 10.8 USG / 40.9 L

Tare weight: 6.82 lbs. / 3.1 kgs.

Colors

Standard: White, Black and Natural

Custom: Available at manufacturer's discretion

Decorating Options

Four color offset printing

Print area: 35 6/4"W X 11"H

Sleeve or pressure sensitive labeling

Shipping Data

Qty. per pallet/carton:

Bodies

108*

Covers

594*

Gross Weight (lbs./kgs.)**:

594/269.4

784/355.6

Length (in./cm.):

47/119.4

47/119.4

Width (in./cm.):

47/119.4

47/119.4

Height (in./cm.):

93/236.2

87/220.9

Approximate truckload quantity of 2,592 pails and covers***

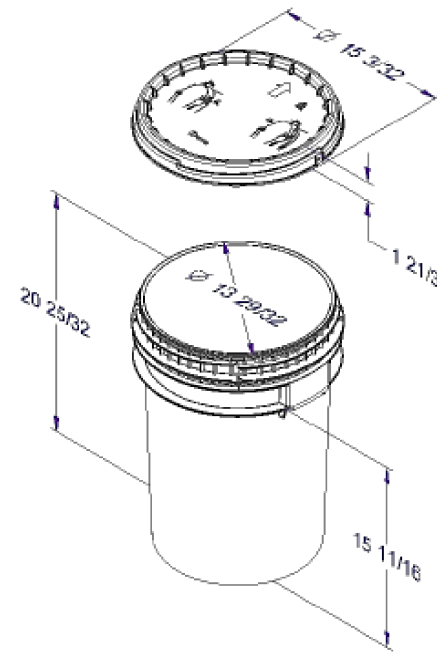

Filled Containers

36 (12 per layer/3 layers high)

Pallet height: 63"

Notes:

*Quantity can vary based on customer request

**Weight does not include pallet/packaging

***Based on 53' trailer and full pallet quantities

Materials

FDA approved materials

Resin: Body: High-Density Polyethylene (HDPE)

Cover: High-Density Polyethylene (HDPE)

MSDS Sheets available upon request

Carrying Handle – Molded in grip

DISCLAIMER

THIS INFORMATION IS PROVIDED AS A GENERAL GUIDE, INCLUDING DIMENSIONS. IT IS THE CUSTOMER'S RESPONSIBILITIES TO SELECT THE PROPER CONTAINER FOR PRODUCT AND APPLICATION COMPATIBILITY.

DISTRIBUTED BY:



DWG NO.:

DWG10145

DESCRIPTION:

10.7 gallon HDPE Open Head Pail