

NOTES:

1. MATERIAL: HIGH DENSITY POLYETHYLENE, BLUE WHITE
2. NOMINAL WALL THICKNESS: .100" EXCEPT PAIL BOTTOM & LOWER 3" OF SIDEWALLS TO BE .120".
3. RATED VOLUME: 11.5 GAL'S
 VOLUME TO OVERFLOW: 12.6 GAL'S
 MAX. ALLOWABLE GROSS WT.: 110 LBS (50 KG)
4. WHEN MATED WITH C-10012 COVER, PACKAGE COMPLIES WITH U.N. PACKING GROUP II REQUIREMENTS FOR SOLIDS PACKAGING (49 CFR 178.600 THRU 178.604). AND CHILD RESISTANT / SENIOR FRIENDLY REQUIREMENTS OF 16 CFR 1700 AND 40 CFR 157.

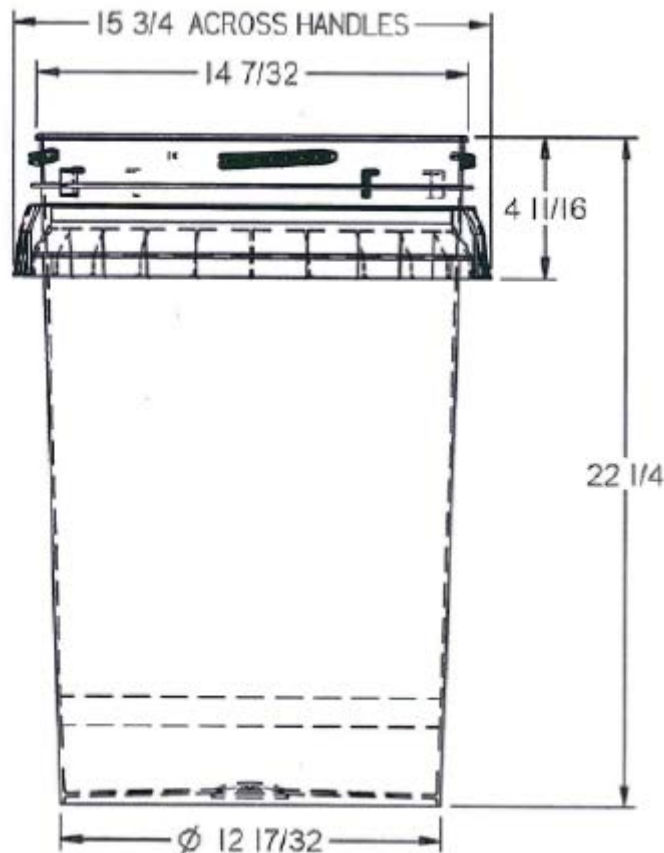

DISCLAIMER

THIS INFORMATION IS PROVIDED AS A GENERAL GUIDE, INCLUDING DIMENSIONS. IT IS THE CUSTOMER'S RESPONSIBILITIES TO SELECT THE PROPER CONTAINER FOR PRODUCT AND APPLICATION COMPATIBILITY.

DISTRIBUTED BY:



REF NO.:

DESCRIPTION: