

12.2 Gallon Screw Top ST3 Pail with Cover

Note: *UN Solids rated to Y59.0/S

Multiple Uses
 Dry Products

Product Codes
 Pail: 9900 Series
 Description: 12.2 Gallon Screw Top Pail

Cover: 8900 Series
 Description: 12.2 Gallon Screw Top Cover

Features

Gauge: 100 mil
 Nominal capacity: 12.2 USG / 46.2 L
 Stack performance: 350 lbs.*
 Tare weights: Body: 5.84 lbs. / 2,650 gr.
 Cover: 1.45 lbs. / 660 gr.

Note: *Ratings will be reduced with uneven load distribution.

Specifications with Cover

Dimensions: 16 1/8" D. X 21 1/4" H
 Maximum capacity: 12.3 USG / 46.5 L
 Tare weight: 7.29 lbs. / 3.3 kgs.

Colors

Standard: White, Black and Natural
 Custom: Available at manufacturer's discretion

Decorating Options

Four color offset printing
 Print area: 36"W X 11 3/4"H
 Sleeve or pressure sensitive labeling

| Shipping Data | Bodies | Covers | Filled Containers |
|---|-----------|-----------|---------------------------------|
| Qty. per pallet/carton: | 108* | 594* | 36 (12 per layer/3 layers high) |
| Gross Weight (lbs/kgs.)**: | 594/269.4 | 784/355.6 | Pallet height: 63 5/16" |
| Length (in./cm.): | 47/119.4 | 47/119.4 | |
| Width (in./cm.): | 47/119.4 | 47/119.4 | |
| Height (in./cm.): | 93/236.2 | 87/220.9 | |
| Approximate truckload quantity of 2,592 pails and covers*** | | | |

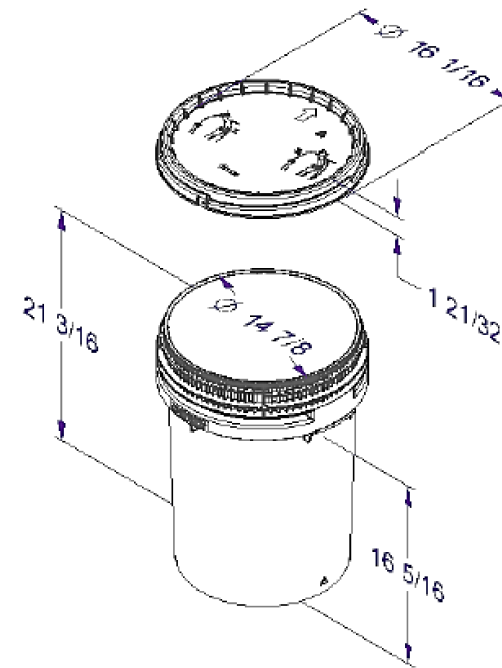

Materials

FDA approved materials
 Resin: Body: High-Density Polyethylene (HDPE)
 Cover: High-Density Polyethylene (HDPE)

| | | |
|---|---|----------------------|
| DISCLAIMER THIS INFORMATION IS PROVIDED AS A GENERAL GUIDE, INCLUDING DIMENSIONS. IT IS THE CUSTOMER'S RESPONSIBILITIES TO SELECT THE PROPER CONTAINER FOR PRODUCT AND APPLICATION COMPATIBILITY. | DISTRIBUTED BY:  | REF NO.: DWG10146 |
| | DESCRIPTION: 12.2 gallon HDPE Open Head Pail | |