

5.0 Gallon 100 mil Pail with Tear Skirt Cover

Multiple Uses

Dry Products

Product Codes

Container: **5500 Series, 5556**

Description: 5.0 gallon 100 mil Pail

Cover: **6500 Series**

Description: Standard Tear Skirt Cover

Note: *Multiple fitting and venting options available

Features

Gauge: 100 mil.

Nominal capacity: 5.0 USG / 19.0 L

Stack performance: 200 lbs.*

Tare weights: Body: 2.31 lbs. / 1.050 kgs

Cover: .66 lbs. / .300 kgs.

Note: *Ratings will be reduced with uneven load distribution.

Specifications with Cover

Dimensions: 12-3/8" D X 14-11/16"H

Maximum capacity: 5.36 USG / 21.2 L

Tare weight: 2.98 lbs. / 1.35 kgs.

Colors

Standard: White, Black and Natural

Custom: Available at manufacturer's discretion

Decorating Options

Four color offset printing

Print area: 33"W x 8-1/2"H

Sleeve or pressure sensitive labeling

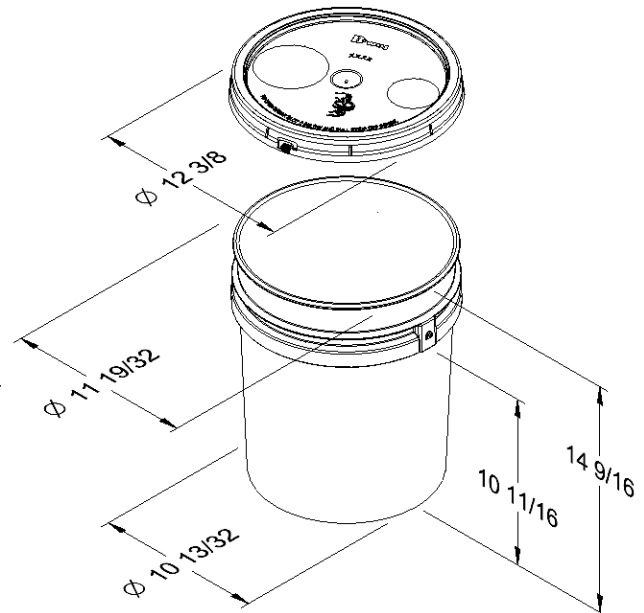

Shipping Data

Qty. per pallet/carton:

Gross Weight (lbs/kgs.)**:

Length (in./cm.):

Width (in./cm.):

Height (in./cm.):

Bodies

240*

420 / 190.5

48 / 122

36 / 91.4

45 / 114

Covers

1,200*

792 / 359

50 / 127

37.5 / 95.3

96 / 243.8

Filled Containers

36 (12 per layer / 3 layers high)

Pallet Height: 47"

Estimated truckload quantity of 5,520 bodies and covers***

Notes: *Quantity can vary based on customer request

**Weight does not include pallet/packaging

***Truckload quantity based on 53' trailer

Materials

FDA approved materials

Resin: Body: High-Density Polyethylene (HDPE)

Cover: High-Density Polyethylene (HDPE)

MSDS Sheets available upon request

Optional Carrying Handle

Wire or Plastic

DISTRIBUTED BY:



REF NO.:

DWG30579

DESCRIPTION:

5 Gallon HDPE Open Head Pail

DISCLAIMER

THIS INFORMATION IS PROVIDED AS A GENERAL GUIDE, INCLUDING DIMENSIONS. IT IS THE CUSTOMER'S RESPONSIBILITIES TO SELECT THE PROPER CONTAINER FOR PRODUCT AND APPLICATION COMPATIBILITY.