

# 5.0-Gallon 90 mil LBR Pail with Standard Tear Skirt Cover

*\*Note: Available with UN-Solids Y27/S rating for Packaging Group II and III (USA & Canada)*

## Multiple Uses

Dry Products  
Liquid Products

## Product Codes

Pail: 5500 Series, 55100  
Description: 5.0-gallon LBR Pail  
  
Cover: 6500 Series  
Description: Tear Skirt Cover, Standard  
*Note: \*Multiple fitting and venting options available*

## Features

Gauge: 90 mil  
Nominal capacity: 5.0 USG / 19.0 L  
Stack performance: 350 lbs.\*  
Tare weights: Body: 2.08 lbs. / 948 gr.  
Cover: .66 lbs. / 300 gr.  
*Note: \*Ratings will be reduced with uneven load distribution.*

## Specifications with Cover

Dimensions: 12 3/8" D. X 14 11/16" H  
Maximum capacity: 5.3 USG / 21.2L  
Tare weight: 2.74 lbs. / 1.25 kgs.

## Colors

Standard: White, Black and Natural  
Custom: Available at manufacturer's discretion

## Decorating Options

Four color offset printing  
Print area: 33"W X 8-1/2"H  
Sleeve or pressure sensitive labeling

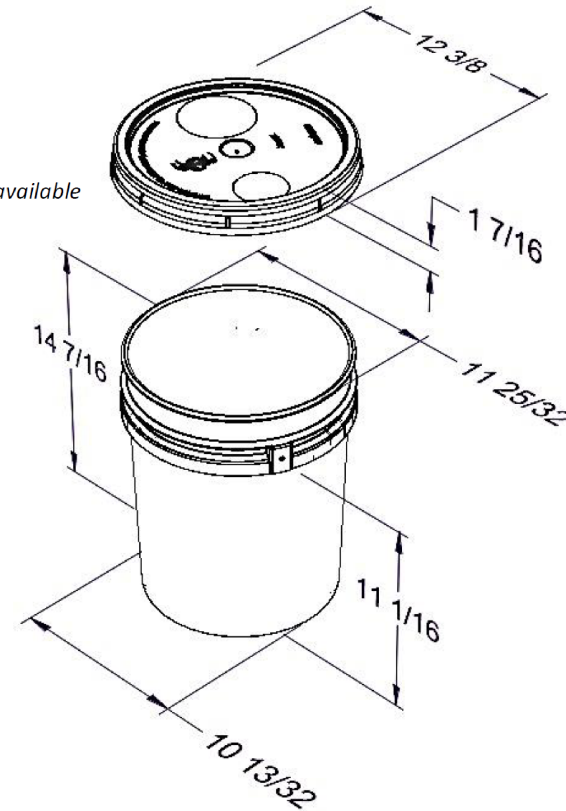

## Shipping Data

|   | Bodies    | Covers    |
|---|-----------|-----------|
| Qty. per pallet/carton:                                     | 240*      | 1,200*    |
| Gross Weight (lbs./kgs.)**:                                 | 499.2/226 | 792/359   |
| Length (in./cm.):   | 48/122    | 50/127    |
| Width (in./cm.):  | 36/91.4   | 37.5/95.3 |
| Height (in./cm.):   | 45/114    | 96/243.8  |
| Approximate truckload quantity of 5,520 pails and covers*** |           |           |

## Filled Containers

36 (12 per layer/3 layers high)  
Pallet height: 47"

## Notes:

- \*Quantity can vary based on customer request
- \*\*Weight does not include pallet/packaging
- \*\*\*Based on 53' trailer and full pallet quantities

## Materials

FDA approved materials  
Resin: Body: High-Density Polyethylene (HDPE) Cover: High-Density Polyethylene (HDPE)  
MSDS Sheets available upon request

**Optional Carrying Handle** – Wire or Plastic

## DISCLAIMER

THIS INFORMATION IS PROVIDED AS A GENERAL GUIDE, INCLUDING DIMENSIONS. IT IS THE CUSTOMER'S RESPONSIBILITIES TO SELECT THE PROPER CONTAINER FOR PRODUCT AND APPLICATION COMPATIBILITY.

DISTRIBUTED BY:



DWG NO.:

DWG10171

DESCRIPTION:

5 gallon HDPE Open Head Pail