

4.25-Gallon EZ STOR® Container with Hinged Cover

Multiple Uses

Dry Products

Product Codes

Container: **E427**

Description: 4.25-gallon rectangular can

Cover: **E4DH**

Description: Dry seal, tamper-evident, hinged, EZ open & close cover

Features

Built in hand grips
 Gauge: 65 mil.
 Nominal capacity: 4.25 USG / 16 L
 Stack performance: 150 lbs.*
 Tare weights: Body: 1.33 lbs. / .61 kgs.
 Cover: .42 lbs. / .19 kgs.

Note: *Ratings will be reduced with uneven load distribution.

Specifications with Cover

Dimensions: 12"L X 9-15/16"W X 13-11/16"H
 Maximum capacity: 4.5 USG / 17 L
 Tare weight: 1.75 lbs. / .80 kgs.

Colors

Standard: White, Black and Natural
 Custom: Available at manufacturer's discretion

Decorating Options*

Four or six color offset printing**
 Sleeve or pressure sensitive labeling
 NXT Graphics®

Note: *See EZ Stor Decoration Summary for further details.
 **Where available.

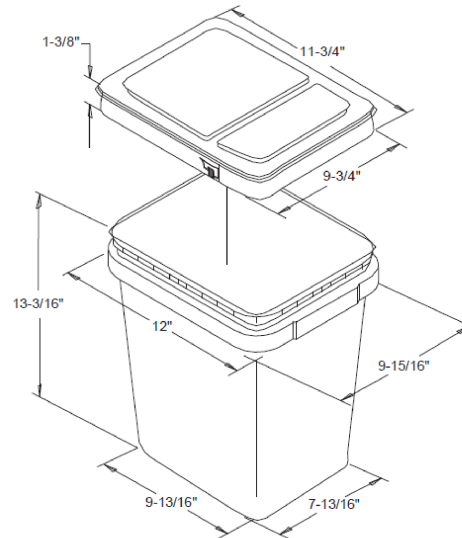

Shipping Data

Qty. per pallet: 288
 Gross Weight (lbs./kgs.)**: 383/176
 Den. (lbs./C.F./kgs./m3): 6.7/109.8
 Length (in./cm.): 48.0/121.9
 Width (in./cm.): 40.0/101.6
 Height (in./cm.): 51.0/129.5

Bodies

288
 383/176
 6.7/109.8
 48.0/121.9
 40.0/101.6
 51.0/129.5

Covers

2,304 (32 boxes of 72)*
 976.6/437.7
 11.7/187.3
 47/119.4
 41/104.1
 74/188

Filled Containers

48 (16 per layer/3 layers high)
 Pallet height: 45.95"

Estimated truckload quantity of 12,672 bodies and covers***

Note: *Bulkpack of 1120 also available

**Weight does not include pallet / packaging

***Truckload quantity based on 53' trailer

Materials

FDA approved materials
 Resin: Body: High Density Polyethylene (HDPE)
 Cover: Polypropylene (PP)

Optional Carrying Handle

DISCLAIMER

THIS INFORMATION IS PROVIDED AS A GENERAL GUIDE, INCLUDING DIMENSIONS. IT IS THE CUSTOMER'S RESPONSIBILITIES TO SELECT THE PROPER CONTAINER FOR PRODUCT AND APPLICATION COMPATIBILITY.

DISTRIBUTED BY:



DWG NO.:

DWG10151

DESCRIPTION:

4.25 gallon HDPE EZ Stor Pail