

20.0 Liter Square Tight Head with Integrated Handle

Product Uses

Liquid Products

Product Codes

Square Tight Head: **STH Series**

Multiple Neck Finishes and Vent Options

Features

UN Rating: 3H1/Y1.8/100

Nominal capacity: 5.28 USG / 20.0 L

Maximum capacity: 5.65 USG / 21.40 L

Colors

Standard: White, Black, Blue and Natural

Custom: Available at manufacturer's discretion

Decorating Options

Maximum Print Area:

Perimeter = 38-1/4" X 8-11/16"H

Containers can be decorated; See Salesperson for Options

Materials

FDA approved materials

Resin: HDPE

MSDS Sheets and Technical Bulletin available upon request

Handle – Integrated into Body

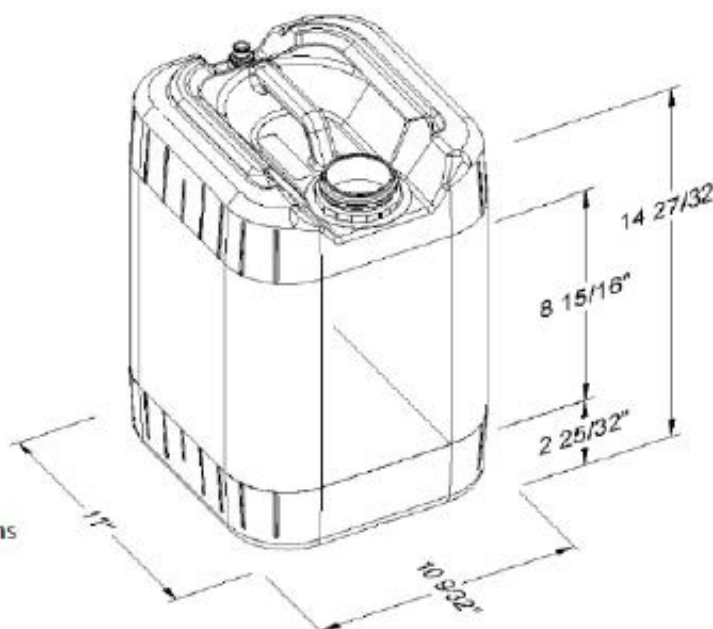

Shipping Data:

Qty. per floor spot*:

Gross Weight (lbs./kgs.)**:

Length (in./cm.):

Width (in./cm.):

Height (in./cm.):

Approximate truckload quantity of 3360 pails and covers***

Containers

112

306 / 139

44 / 112

33 / 84

107 / 273

Filled Containers

Refer to BWAY document #ETS-CD-1002 for storage and shipping recommendations.

Notes:

*Quantity can vary based on customer request

**Weight does not include pallet/packaging

***Based on 53' trailer and standard pallet quantities

DISCLAIMER

THIS INFORMATION IS PROVIDED AS A GENERAL GUIDE, INCLUDING DIMENSIONS. IT IS THE CUSTOMER'S RESPONSIBILITIES TO SELECT THE PROPER CONTAINER FOR PRODUCT AND APPLICATION COMPATIBILITY.

DISTRIBUTED BY:



REF NO.:

DESCRIPTION: