

Features

UN Rating: Customer Dependent
Nominal capacity: 5.2 USG / 19.7L
Maximum capacity: 5.5 USG / 20.8 L
Tare weights: 2.57 lbs / 1.17 kgs

Colors

Standard: White, Black, Blue and Natural
Custom: Available at manufacturer's discretion

Decorating Options

Options not available for this product

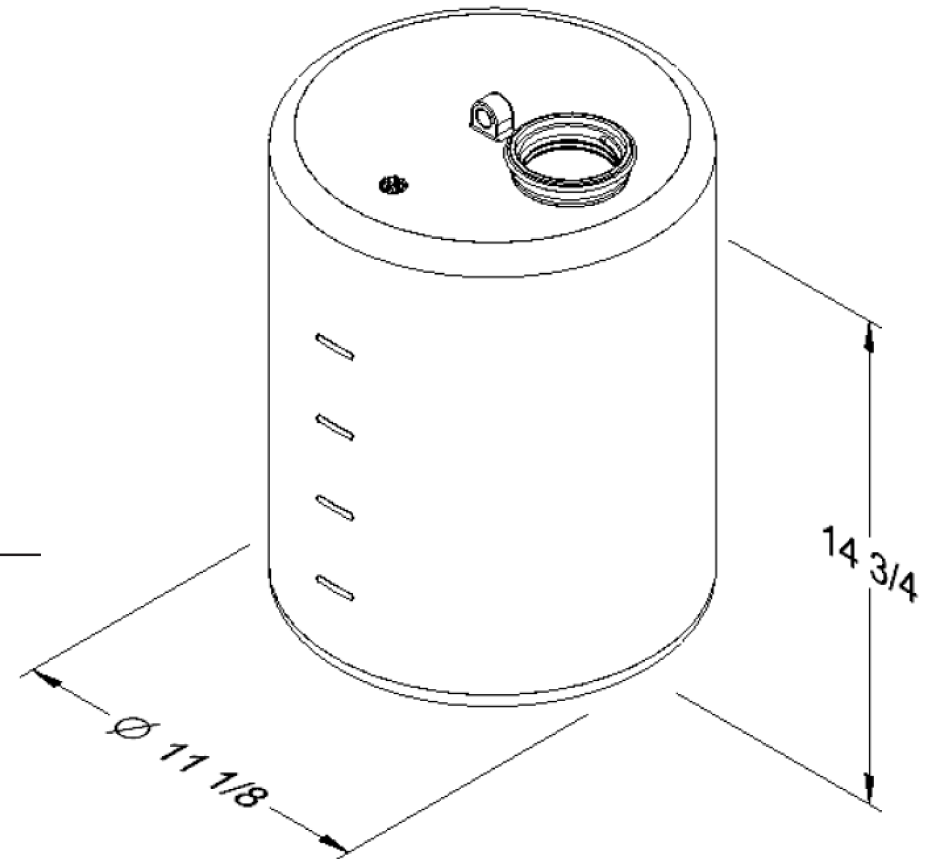

Materials

FDA approved materials
Resin: Body: High-Density Polyethylene (HDPE)
Swing Handle/Pin: High-Density Polyethylene (HDPE)

MSDS Sheets available upon request

Optional Carrying Handle

Swing Handle with Pin

DISCLAIMER

THIS INFORMATION IS PROVIDED AS A GENERAL GUIDE, INCLUDING DIMENSIONS. IT IS THE CUSTOMER'S RESPONSIBILITIES TO SELECT THE PROPER CONTAINER FOR PRODUCT AND APPLICATION COMPATIBILITY.

DISTRIBUTED BY:



REF NO.:

DWG10293

DESCRIPTION:

5 gallon HDPE Round Delpak