

# 20.0 Liter Square Tight Head with Integrated Handle

## Product Uses

Liquid Products

## Product Codes

Container: **STH Series**

Description: 20L Square Tighthead

## Features

UN Rating: 3H1/Y1.8/100

Nominal capacity: 5.3 USG / 20.0L

Maximum capacity: 5.65 USG / 21.4 L

Tare weights: 2.73 lbs / 1.24 kgs

## Colors

Standard: White, Black, Blue and Natural

Custom: Available at manufacturer's discretion

## Decorating Options

Maximum Label Area:

Perimeter: 38-1/4" x 8-11/16" H

See Salesperson for Options

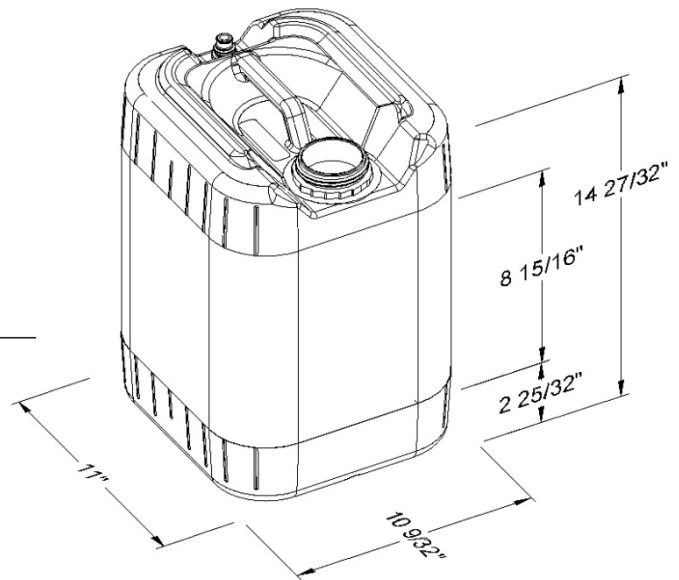

## Shipping Data

Qty. per floor spot:

Gross Weight (lbs./kgs)\*:

Length (in./cm.):

Width (in./cm.):

Height (in./cm.):

## Containers

112

306 / 139

44 / 112

33 / 84

107 / 273

Estimated truckload quantity of 3,360 containers\*\*

Notes: \*Weight does not include pallet / packaging

\*\*Truckload quantity based on 53' trailer

## Materials

FDA approved materials

Resin: Body: High-Density Polyethylene (HDPE)

## Optional Carrying Handle

Integral

DISTRIBUTED BY:



REF NO.:

DWG31230

DESCRIPTION:

20 Liter Blue HDPE Plastic Square TH Pail w/ Integral Handle, 70 MM RXT Fittings

## DISCLAIMER

THIS INFORMATION IS PROVIDED AS A GENERAL GUIDE, INCLUDING DIMENSIONS. IT IS THE CUSTOMER'S RESPONSIBILITIES TO SELECT THE PROPER CONTAINER FOR PRODUCT AND APPLICATION COMPATIBILITY.