

Features

UN Rating: 3H1/Y1.8/100
Nominal capacity: 5.0 USG / 18.9L
Maximum capacity: 5.3 USG / 20.1 L
Tare weights: 2.61 lbs / 1.18 kgs

Colors

Standard: White, Blue and Natural
Custom: Available at manufacturer's discretion

Decorating Options

Maximum Label Area:
Perimeter: 38-1/4" x 8-1/4" H
See Salesperson for Options

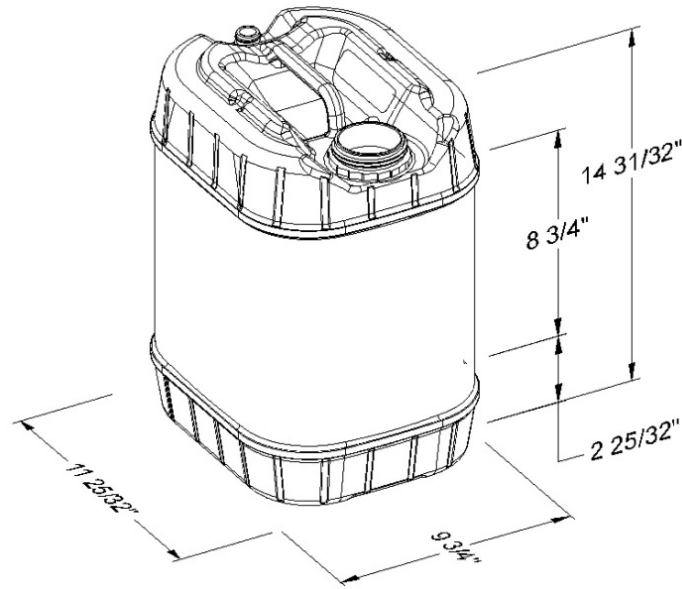

Shipping Data

Gross Weight (lbs./kgs)*: 304 / 138
Length (in./cm.): 47 / 118
Width (in./cm.): 35.4 / 90
Height (in./cm.): 108 / 274

Estimated truckload quantity of 3,360 containers**

Notes: *Weight does not include pallet / packaging
**Truckload quantity based on 53' trailer

Materials

FDA approved materials
Resin: Body: High-Density Polyethylene (HDPE)

MSDS Sheets available upon request

Optional Carrying Handle

Integral

DISCLAIMER

THIS INFORMATION IS PROVIDED AS A GENERAL GUIDE, INCLUDING DIMENSIONS. IT IS THE CUSTOMER'S RESPONSIBILITIES TO SELECT THE PROPER CONTAINER FOR PRODUCT AND APPLICATION COMPATIBILITY.

DISTRIBUTED BY:



REF NO.:

DWG30173

DESCRIPTION:

5 Gallon Natural HDPE Rectangular TH Pail