

# 6.0 Gallon Rectangular Tight Head with Swing Handle

## Product Uses

Liquid Products

## Product Codes

Container: **RTH Series**

Description: 6.0G Rectangular Tighthead

## Features

UN Rating: 3H1/Y1.5/100

Nominal capacity: 6.0 USG / 22.7L

Maximum capacity: 6.4 USG / 24.1 L

Tare weights: 3.0 lbs / 1.36 kgs

## Colors

Standard: White, Black, Blue and Natural

Custom: Available at manufacturer's discretion

## Decorating Options

Maximum Label Area:

Perimeter: 38-1/4" x 11-3/32" H

See Salesperson for Options

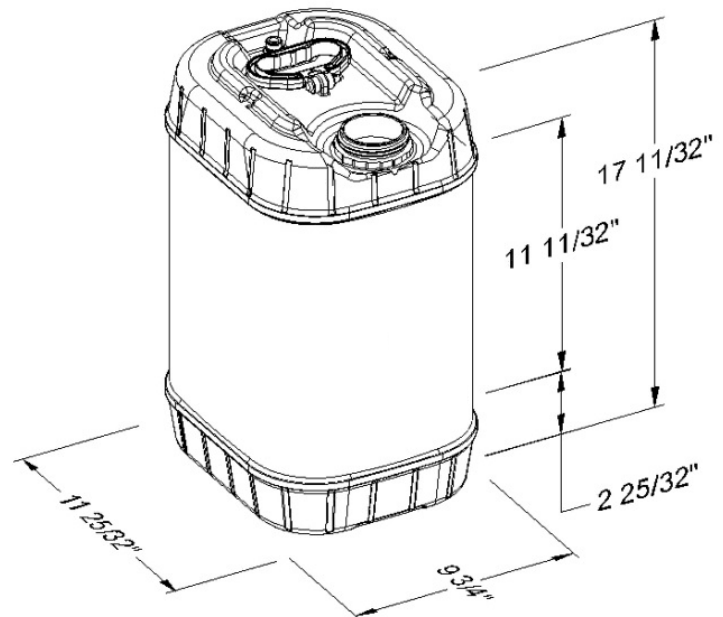

## Shipping Data

Qty. per floor spot:

Gross Weight (lbs./kgs)\*:

Length (in./cm.):

Width (in./cm.):

Height (in./cm.):

## Containers

80

240 / 111

48 / 121

35.3 / 90

91 / 230

## Filled Containers

Refer to BWAY document # ETS-CD-1002

for storage and shipping recommendations.

Estimated truckload quantity of 2,400 containers\*\*

Notes: \*Weight does not include pallet / packaging

\*\*Truckload quantity based on 53' trailer

## Materials

FDA approved materials

Resin: Body: High-Density Polyethylene (HDPE)

Handle/Pin: High-Density Polyethylene (HDPE)

MSDS Sheets available upon request

## Optional Carrying Handle

Swing Handle with Pin

DISTRIBUTED BY:



REF NO.:

DWG30221

DESCRIPTION:

6 Gallon White HDPE Rectangular TH Pail

## DISCLAIMER

THIS INFORMATION IS PROVIDED AS A GENERAL GUIDE, INCLUDING DIMENSIONS. IT IS THE CUSTOMER'S RESPONSIBILITIES TO SELECT THE PROPER CONTAINER FOR PRODUCT AND APPLICATION COMPATIBILITY.