

**Multiple Uses**

Dry Products

**Product Codes**Container: **E659**

Description: 6.5-gallon rectangular can

Cover: **E6DH**Description: Dry seal, tamper-evident, hinged EZ  
open & close cover with Ring Pull®**Features**

Built-in hand grips  
 Gauge: 90 mil.  
 Nominal capacity: 6.5 USG / 24.6 L  
 Stack performance: 300 lbs.\*  
 Tare weights: Body: 2.27 lbs. / 1.03 kgs.  
 Cover: .50 lbs. / .23 kgs.

Note: \*Ratings will be reduced with uneven load distribution.

**Specifications with Cover**

Dimensions: 13-3/8"L X 12"W X 13-13/16"H  
 Maximum capacity: 6.74 USG / 25.5 L  
 Tare weight: 2.77 lbs. / 1.26 kgs.

**Colors**

Standard: White, Black and Natural  
 Custom: Available at manufacturer's discretion

**Decorating Options\***

Four or six color offset printing\*\*  
 Sleeve or pressure sensitive labeling  
 NXT Graphics®

Note: \*See EZ Stor Decoration Summary for further details.

\*\*Where available.

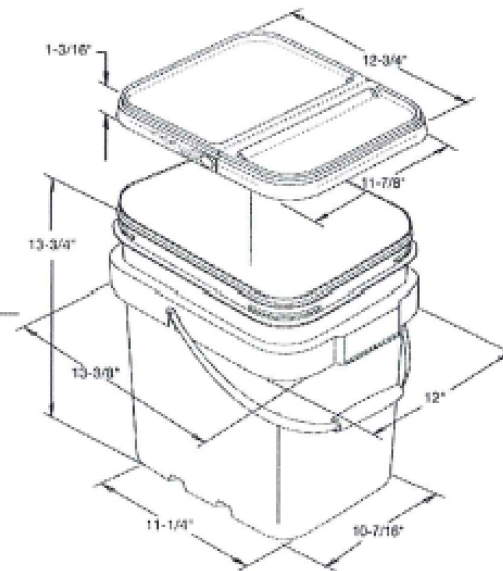
**Shipping Data**

|   | <b>Bodies</b> | <b>Covers</b> |
|---|---------------|---------------|
| Qty. per pallet/carton:                                   | 120           | 600           |
| Gross Weight (lbs./kgs.):*                                | 272.4/123.6   | 300/138       |
| Den. (lbs./C.F./kgs./m3):                                 | 5.1/81.8      | 9.0/146.2     |
| Length (in./cm.):   | 48/121.9      | 48/121.9      |
| Width (in./cm.):  | 40/101.6      | 40/101.6      |
| Height (in./cm.):   | 48/121.9      | 30/76.2       |
| Estimated truckload quantity of 5,760 bodies and covers** |               |               |

**Filled Containers**

36 (12 per layer/3 layers high)  
 Pallet height: 45.9"

Notes: \*Weight does not include pallet / packaging

\*\*Truckload quantity based on 53' trailer

**Materials**

FDA approved materials  
 Resin: Body: High-Density Polyethylene (HDPE)  
 Cover: Polypropylene (PP)  
 MSDS Sheets available upon request

**Optional Carrying Handle****DISCLAIMER**

THIS INFORMATION IS PROVIDED AS A GENERAL GUIDE, INCLUDING DIMENSIONS. IT IS THE CUSTOMER'S RESPONSIBILITIES TO SELECT THE PROPER CONTAINER FOR PRODUCT AND APPLICATION COMPATIBILITY.

DISTRIBUTED BY:



DWG NO.:

DWG10174

DESCRIPTION:

6.5 gallon PP EZ Stor Hinged Cover (Dry Seal)