

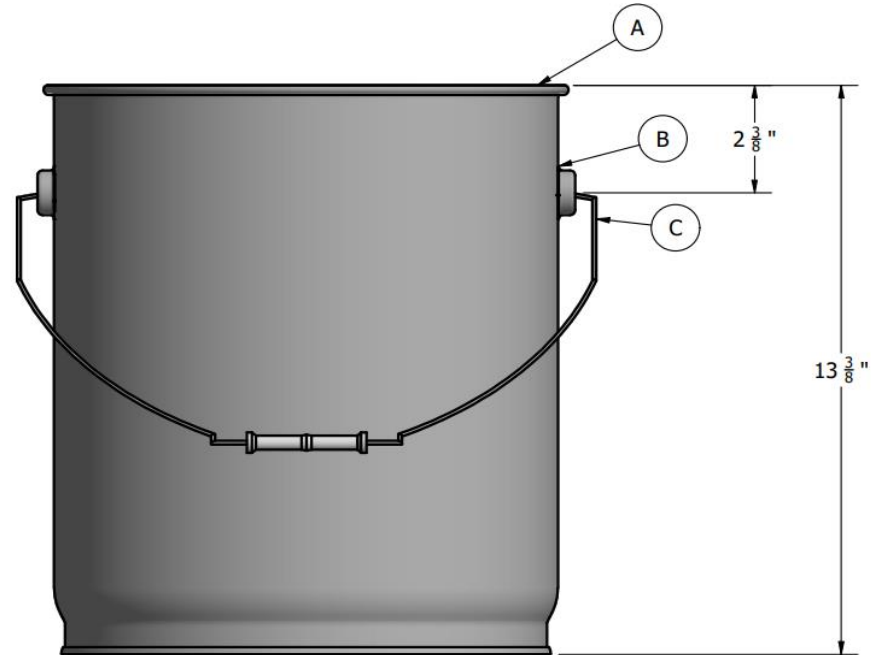

5 Gallon Pail
5 Gallon Open Head Pail Body

Product Description	
Item	Part Description
A	Straight Sided Body Capacity: 5 Gallon Lining Options: Phenolic (Gold & Red-Brown) Epoxy Phenolic (Buff) Rust Inhibitor Enamel Exterior Colors: Black , Grey, White <i>(More Available upon Request)</i> Lithography: Available UN Certifications: Contact Sales Representatives
B	Ear: Optional
C	Handle: Optional



Pail Size Dimensions								
Capacity (Gallon)	Pail Cover Diameter (D)	Pail Height(H)				Quantity Per Pallet		
		No Bead	1 Bead	2 Bead	Bead Height (BH)	No Bead	1 Bead	2 Bead
5	11.25"	13 3/8"	N/A	N/A	N/A	36/48	N/A	N/A

<p align="center">DISCLAIMER</p> <p>THIS INFORMATION IS PROVIDED AS A GENERAL GUIDE, INCLUDING DIMENSIONS. IT IS THE CUSTOMER'S RESPONSIBILITIES TO SELECT THE PROPER CONTAINER FOR PRODUCT AND APPLICATION COMPATIBILITY.</p>	DISTRIBUTED BY:  Pipeline Packaging	REF NO.:
	DESCRIPTION: 5 Gallon Steel Straight Sided Pail with Lug Cover	

Lug Cover

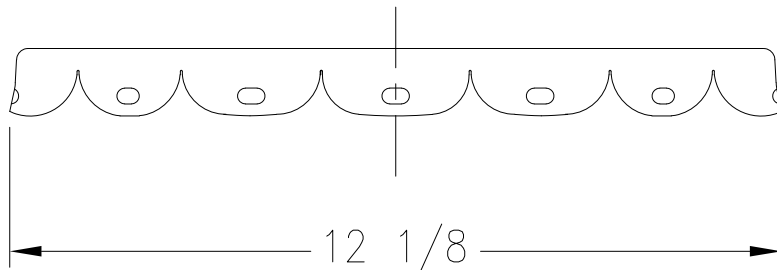
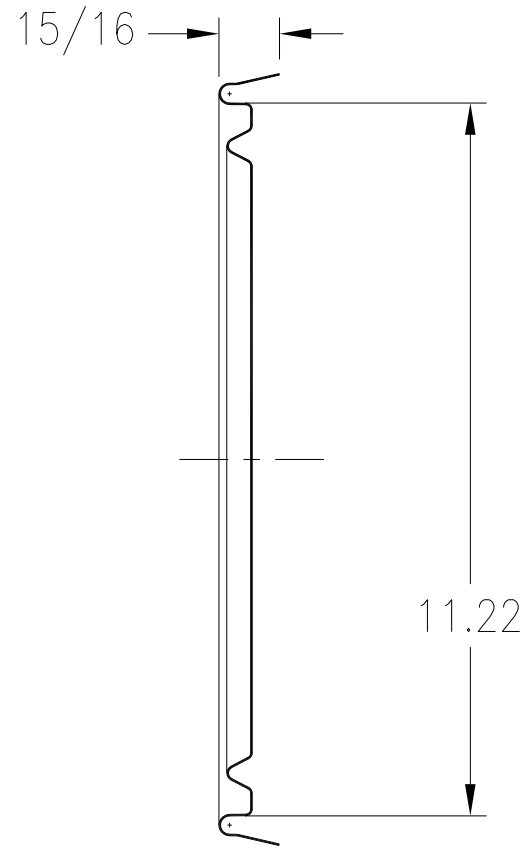
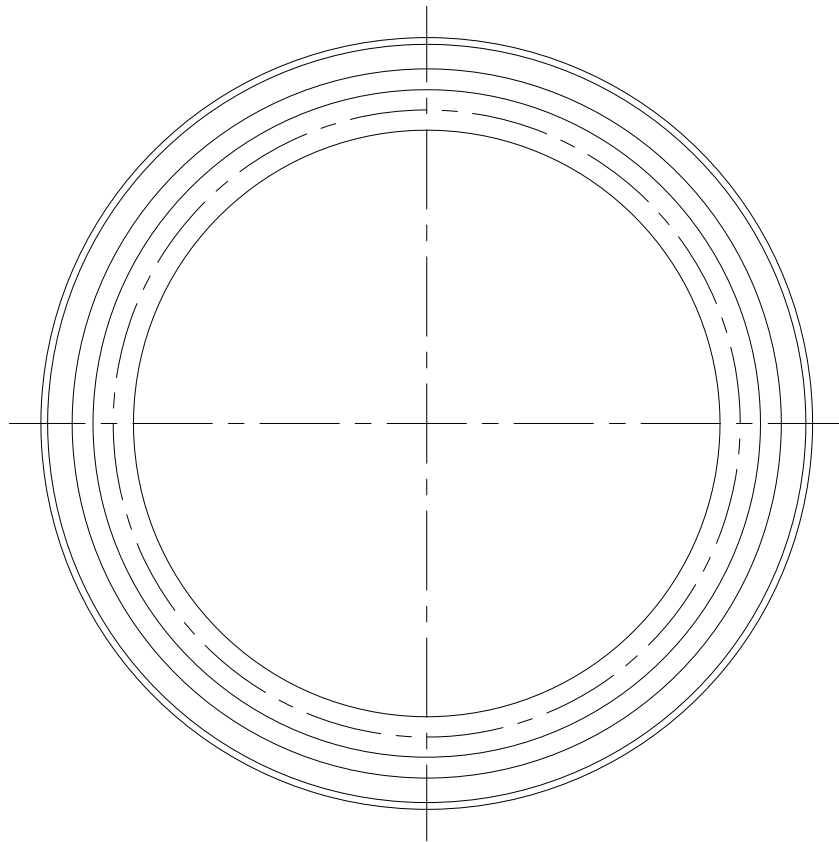

DISCLAIMER

THIS INFORMATION IS PROVIDED AS A GENERAL GUIDE, INCLUDING DIMENSIONS. IT IS THE CUSTOMER'S RESPONSIBILITIES TO SELECT THE PROPER CONTAINER FOR PRODUCT AND APPLICATION COMPATIBILITY.

DISTRIBUTED BY:



REF NO.:

DWG30225

DESCRIPTION:

5 Gallon Steel Straight Sided Pail with Lug Cover