

CSMA TOLERANCES

A	I/S CUP OPENING	1.000 ±.004
B	O/S CUP OPENING	1.221 ±.010
C	CURL HEIGHT OVER DOUBLE SEAM	0.798 ±.016
D	HEIGHT OVER DOUBLE SEAM	6.230 ±.031
E	OVERALL HEIGHT	7.028 ±.035
F	HEIGHT BETWEEN DOUBLE SEAM	5.950 MIN.
G	CURL THICKNESS	0.130 ±.007
K	TOP DOUBLE SEAM DIAMETER	2.700 ±.010

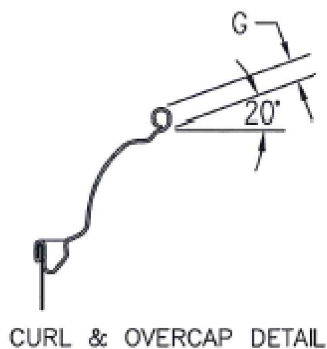
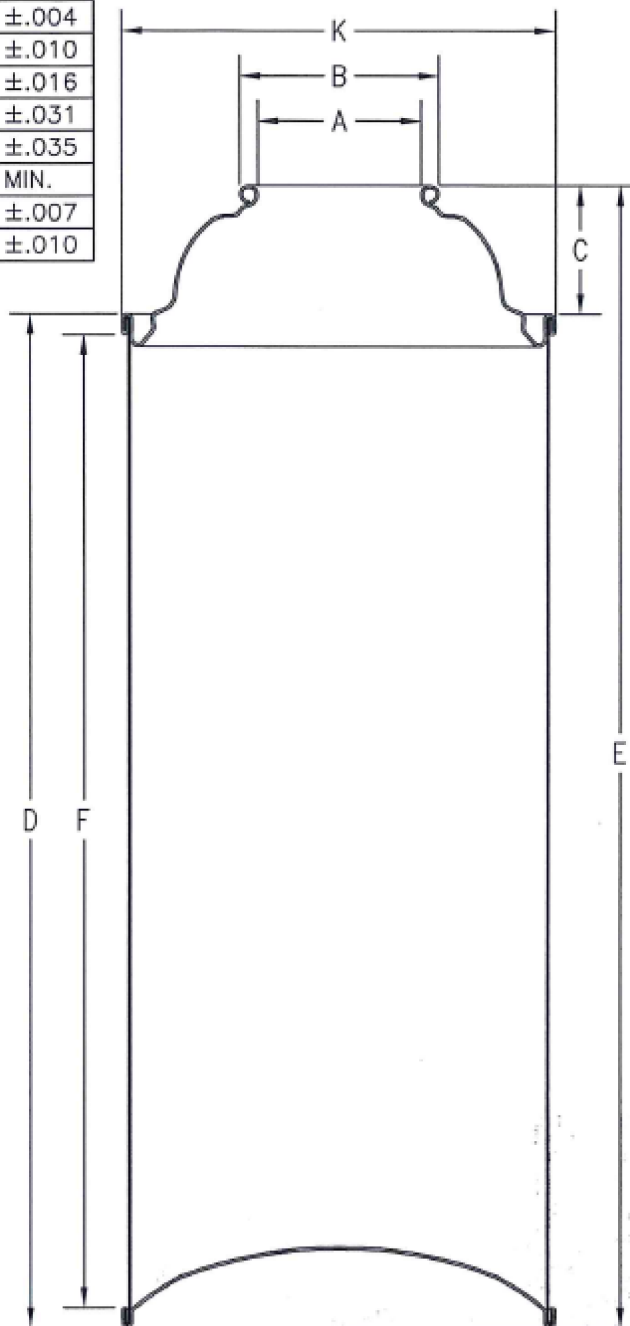

PACK: 2160 CANS PER PALLET

**DISCLAIMER**

THIS INFORMATION IS PROVIDED AS A GENERAL GUIDE, INCLUDING DIMENSIONS. IT IS THE CUSTOMER'S RESPONSIBILITIES TO SELECT THE PROPER CONTAINER FOR PRODUCT AND APPLICATION COMPATIBILITY.

DISTRIBUTED BY:



REF NO.:

DWG10013

DESCRIPTION:

17.6oz Aerosol Can, 211x604