

55 gal Open Head Black Steel Drum with 2" and 3/4" Fittings

NOTE: ALL FLANGES AND PLUGS DESCRIBED IN ISO STANDARDS
 NOTE: ALL DIMENSIONS ARE FOR REFERENCE USE ONLY

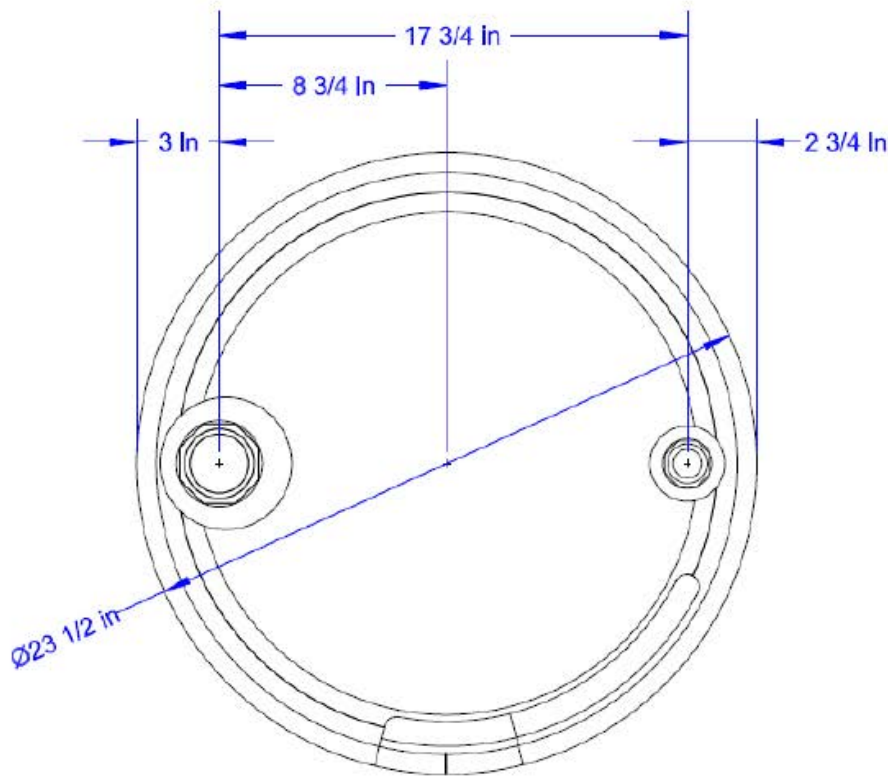
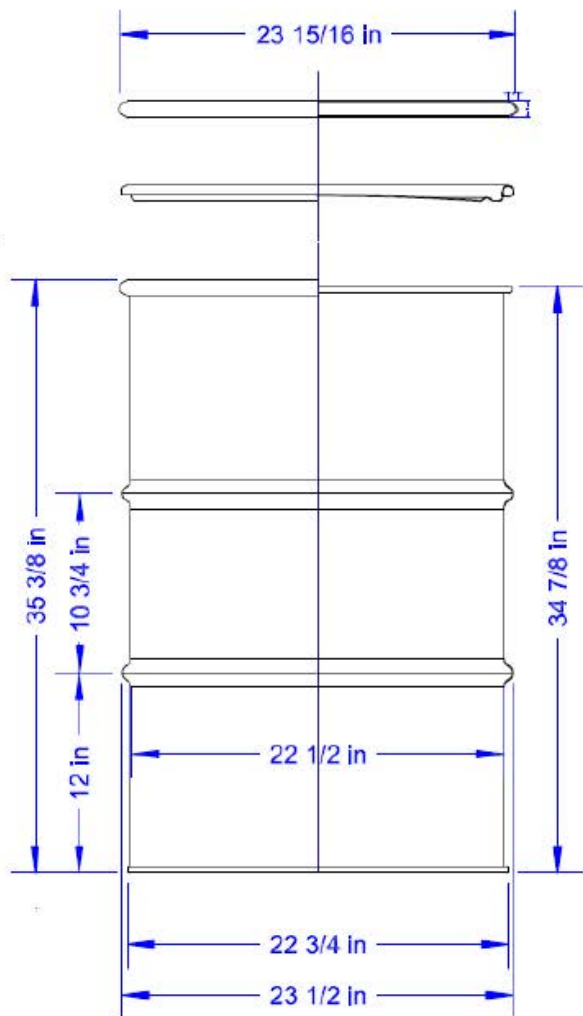

TOP VIEW

DISCLAIMER

THIS INFORMATION IS PROVIDED AS A GENERAL GUIDE, INCLUDING DIMENSIONS. IT IS THE CUSTOMER'S RESPONSIBILITIES TO SELECT THE PROPER CONTAINER FOR PRODUCT AND APPLICATION COMPATIBILITY.

DISTRIBUTED BY:



REF NO.:

DESCRIPTION: