

Ø 1.022 ACROSS TORQUE RAMPS  
TYP. (2 PLACES)

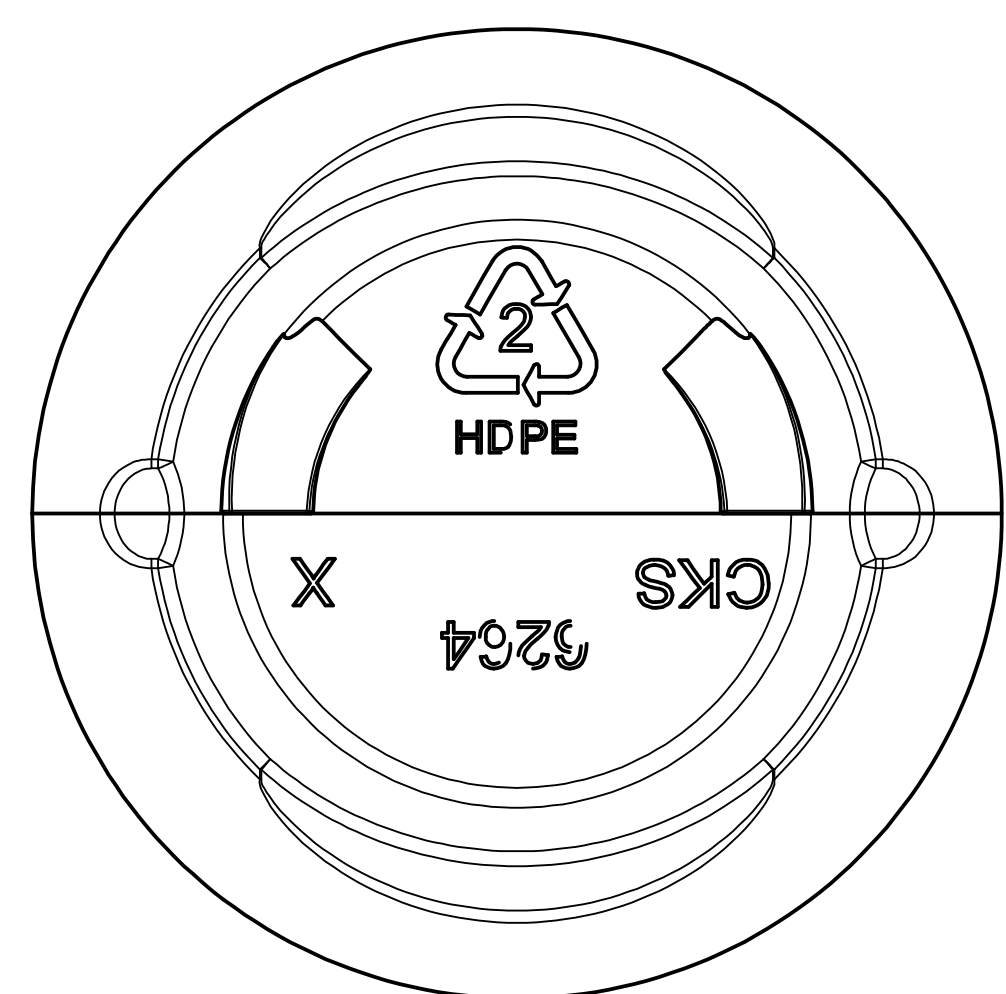
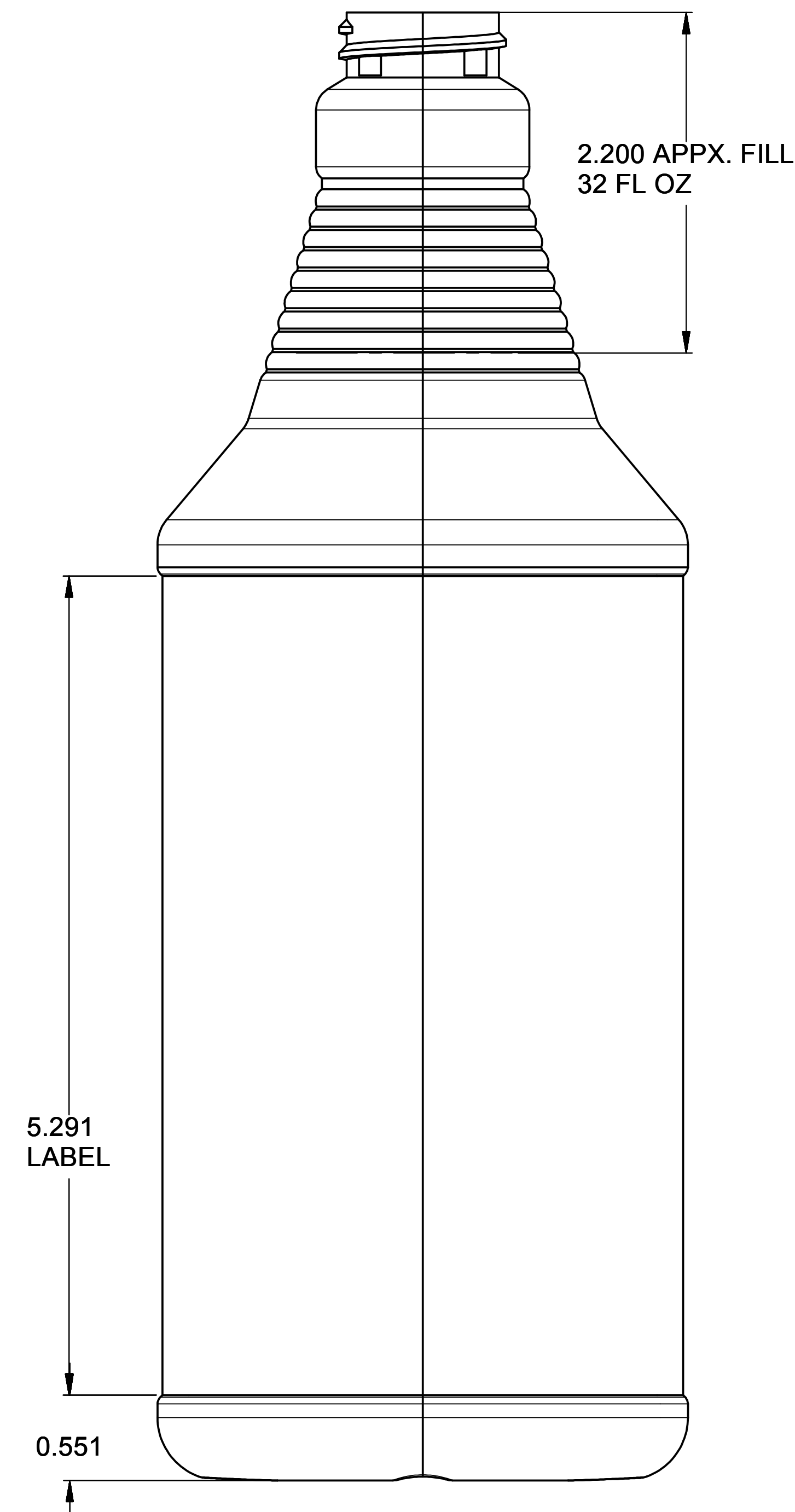
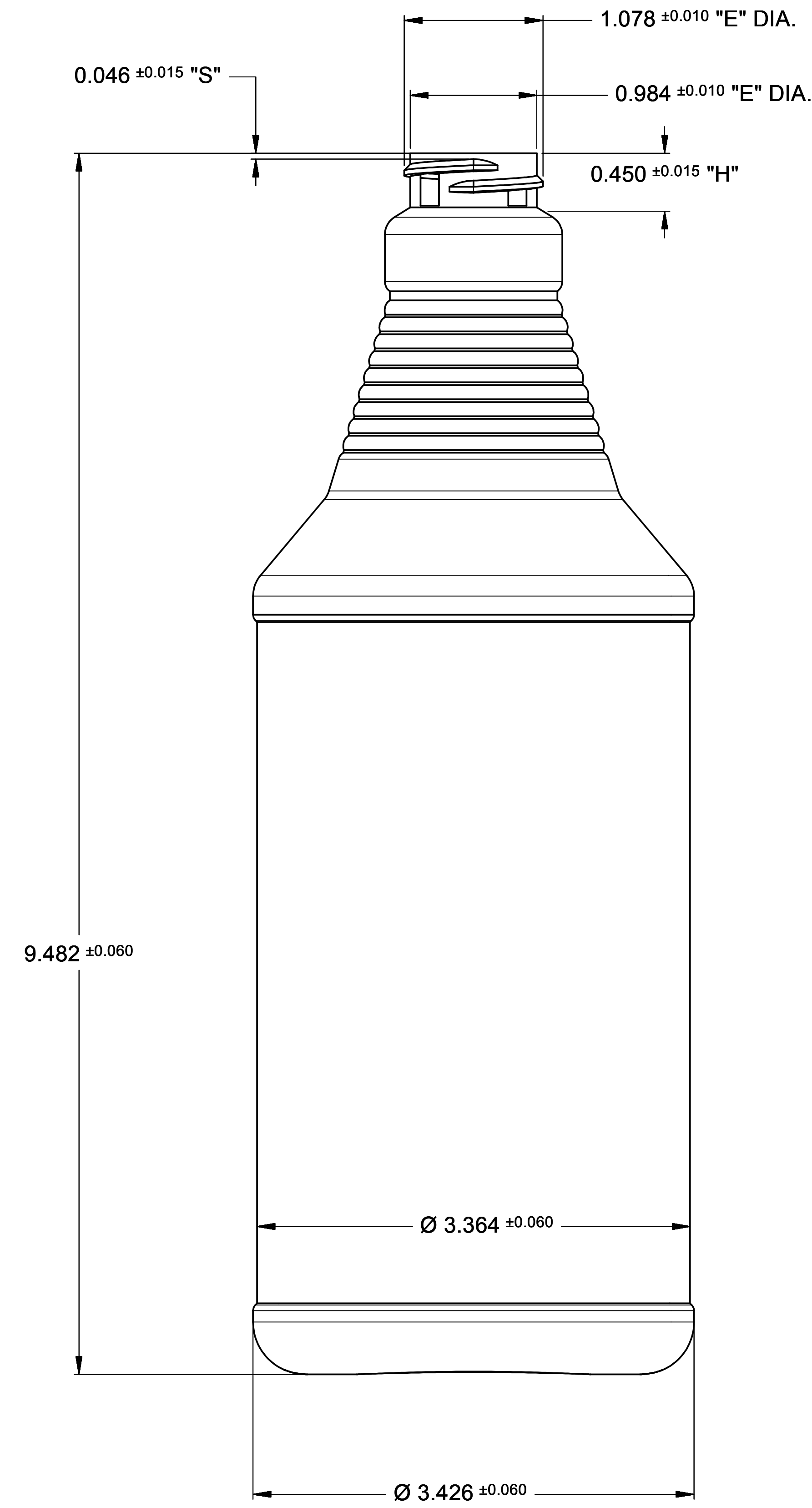

**NOTES:**

1. SCALE: 1:1
2. FINISH: 28-400 SPECIAL "H" WITH TORQUE RAMPS
3. MATERIAL: HDPE
4. GRAM WT.: 54 GRAMS
5. OVERFLOW CAPACITY: 984 ± 15 CC
6. STANDARD S.P.I. TOLERANCES  
APPLY TO ALL BODY DIMENSIONS.

**DISCLAIMER**

THIS INFORMATION IS PROVIDED AS A GENERAL GUIDE, INCLUDING DIMENSIONS. IT IS THE CUSTOMER'S RESPONSIBILITIES TO SELECT THE PROPER CONTAINER FOR PRODUCT AND APPLICATION COMPATIBILITY.

DISTRIBUTED BY:



REF NO.:

DWG31130

DESCRIPTION:

32 oz White HDPE Plastic Ring Neck Carafe Bottle, 28-405, 55 Gram, Big Bulb