

ISOMETRIC VIEW

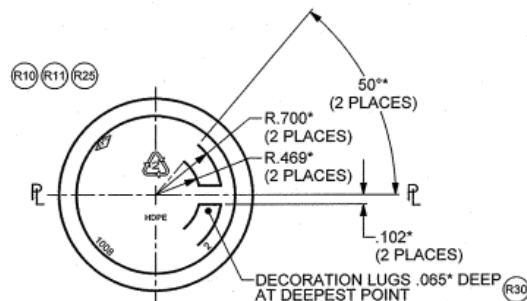
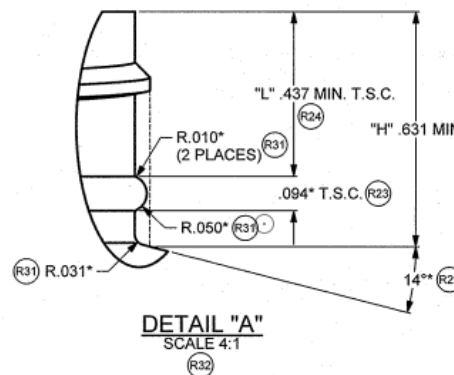
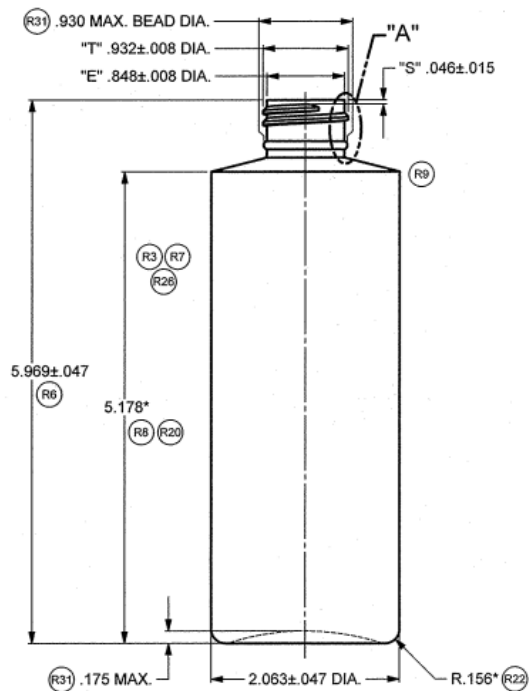

CAPACITY TO OVERFLOW: 268 CC ± 7 CC
 WEIGHT: 20 GM ± 1 GM
 MINIMUM WALL THICKNESS: .020 AT MIDPOINT
 MATERIAL: HDPE

ALL DIMENSIONS ARE IN INCHES.
 DIAMETERS ARE THE AVERAGES OF TWO
 DIMENSIONS TAKEN 90° APART.
 DIMENSIONS LABELED WITH AN "*" ARE
 NON CRITICAL AND FOR REFERENCE
 PURPOSES ONLY.

DISCLAIMER

THIS INFORMATION IS PROVIDED AS A GENERAL GUIDE, INCLUDING DIMENSIONS. IT IS THE CUSTOMER'S RESPONSIBILITIES TO SELECT THE PROPER CONTAINER FOR PRODUCT AND APPLICATION COMPATIBILITY.

DISTRIBUTED BY:



REF NO.:

DWG30683

DESCRIPTION:

8 oz Natural HDPE Cylinder, 24-410