

38mm-REXAM CR SNAPLOK

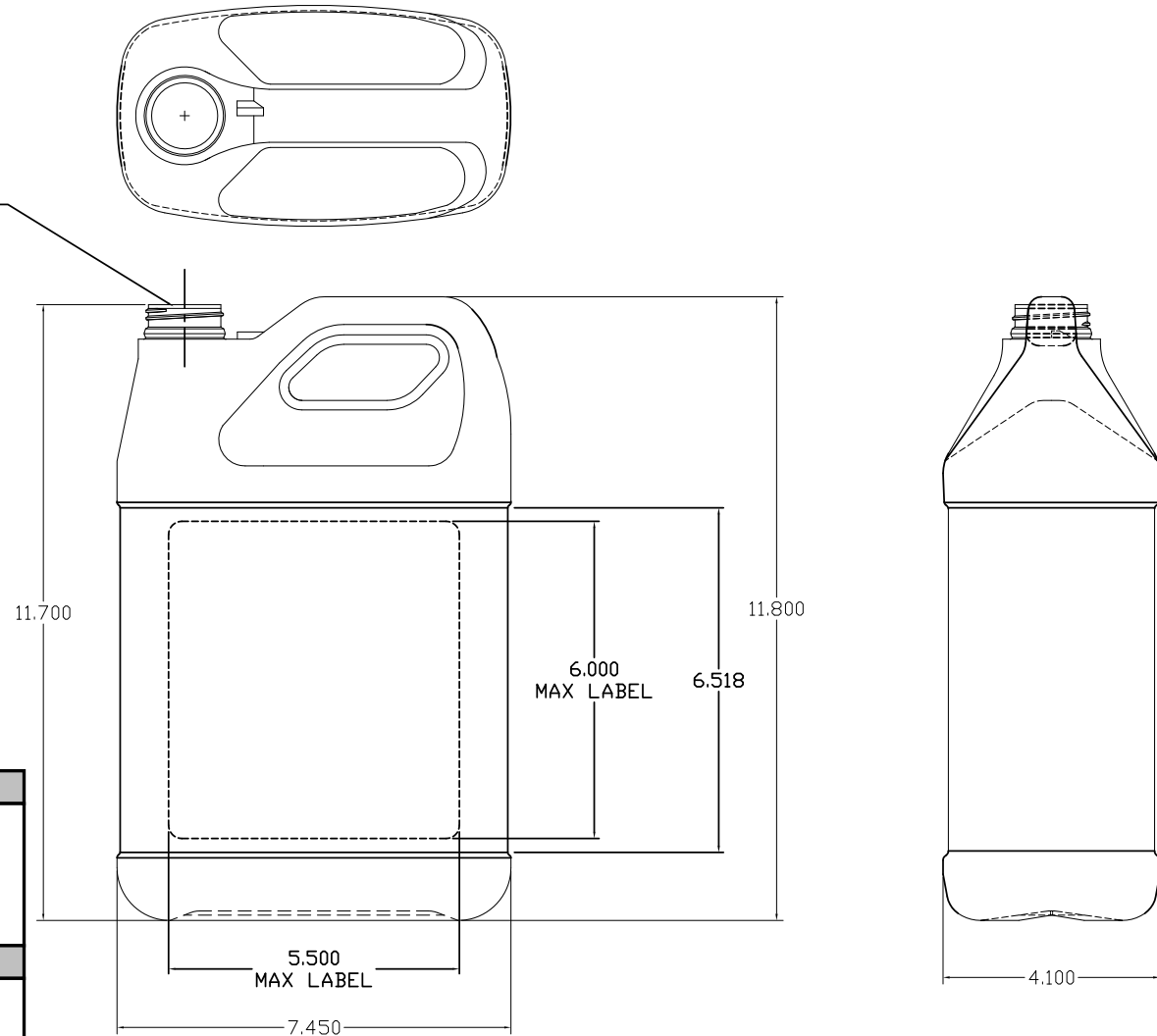

LEE CONTAINER MASTER PRODUCTION SPECIFICATION

CUSTOMER	<u>Stock</u>		
BOTTLE TYPE	<u>Gallon F Trimline</u>	RESIN	<u>B54 - 25H - 127</u>
WEIGHT	<u>150 Grams (+/- 5 g.)</u>	COLOR	<u>White (3943)</u>

BOTTLE DIMENSIONS

NECK I.D.	1.100 Min.	NECK FINISH	Rexam 38mm CR SnapLok
HEIGHT OVER HANDLE	11.800 +/- .080	HEIGHT OVER NECK	11.700 +/- .080
DEPTH	4.100 +/- .080	WIDTH	7.450 +/- .090
E DIMENSION	1.358 - 1.382	*T* DIMENSION	1.452 - 1.476
S DIMENSION	.055 - .085	*H* DIMENSION	.635 - .665
WALL THICKNESS	.015 Min.	Bead Dia.	1.518 - 1.552
		Ratchet Dia.	N/A

DISCLAIMER

THIS INFORMATION IS PROVIDED AS A GENERAL GUIDE, INCLUDING DIMENSIONS. IT IS THE CUSTOMER'S RESPONSIBILITIES TO SELECT THE PROPER CONTAINER FOR PRODUCT AND APPLICATION COMPATIBILITY.

DISTRIBUTED BY:



REF NO.:

DWG31169

DESCRIPTION:

128 oz White HDPE Plastic F-Style, 150 Gram, 38-400 Rexam, CR Snap Lok

Rexam 38 mm CR SnapLok Finish

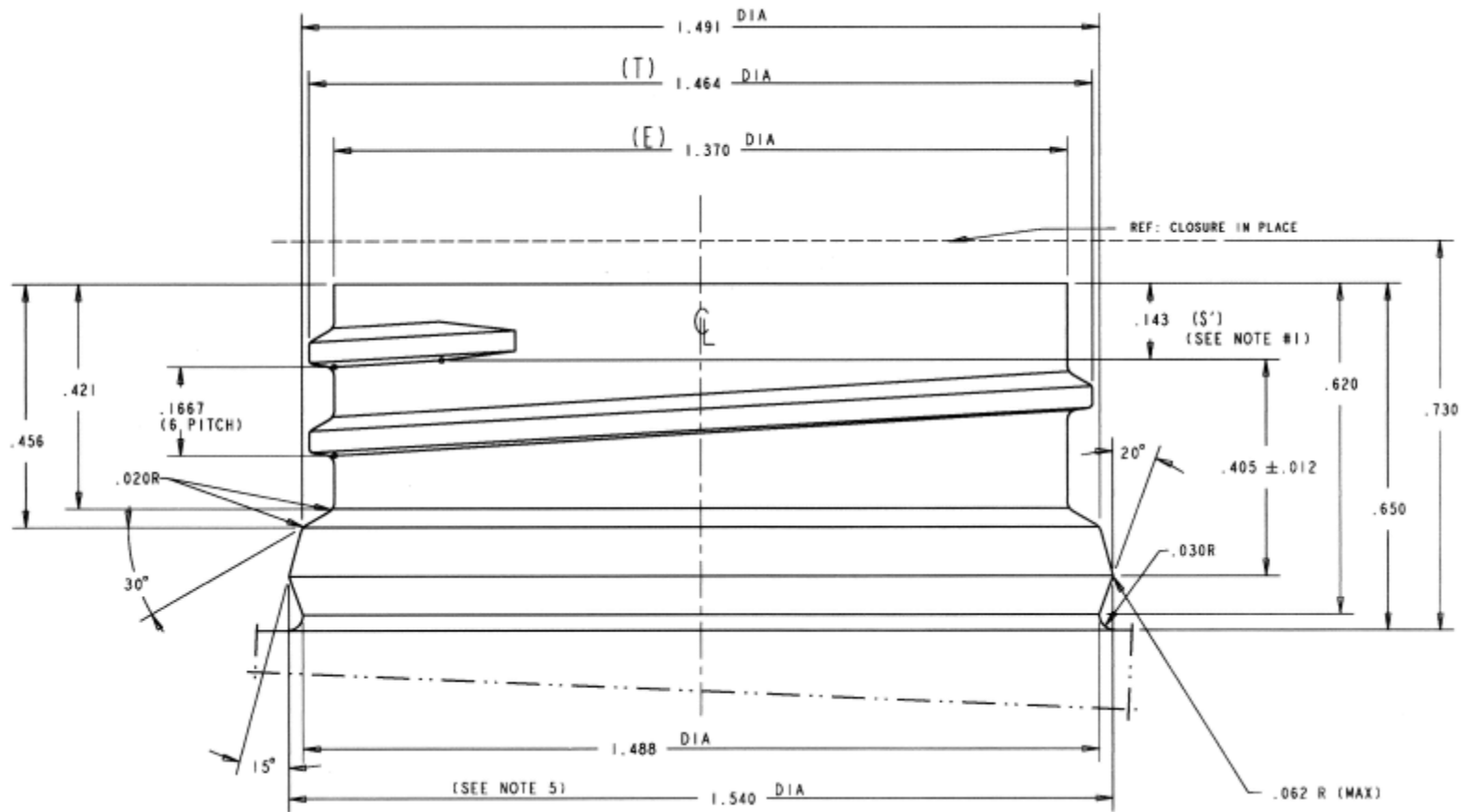

DISCLAIMER
 THIS INFORMATION IS PROVIDED AS A GENERAL GUIDE, INCLUDING DIMENSIONS. IT IS THE CUSTOMER'S RESPONSIBILITIES TO SELECT THE PROPER CONTAINER FOR PRODUCT AND APPLICATION COMPATIBILITY.

DISTRIBUTED BY:		REF NO.:
DESCRIPTION:		DWG31169
128 oz White HDPE Plastic F-Style, 150 Gram, 38-400 Rexam, CR Snap Lok		