

NON LABELED CONTAINER

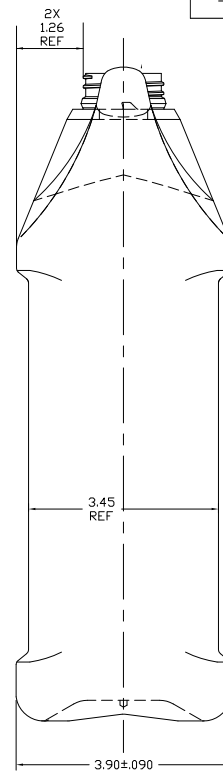

38 MM SPECIAL NECK FINISH

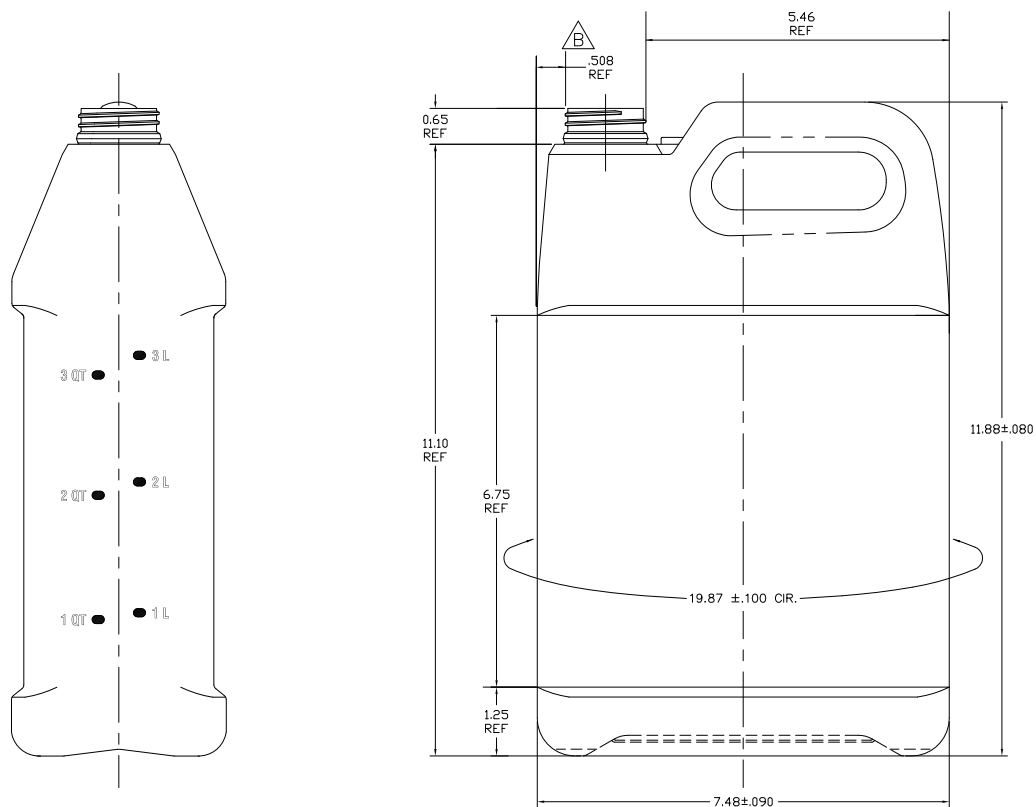
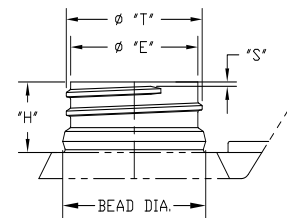

MIN. WALL	.015
"T" DIM.	1.452 / 1.476
"E" DIM.	1.358 / 1.382
"H" DIM.	.635 / .665
"S" DIM.	.031 / .061
"T" DIM. (MIN.)	.987
BEAD DIA.	1.524 +.022/- .012
THREAD TURNS	1-1/2
THREAD LEADS	1
T.P.I.	6
PITCH	.167

CUSTOMER DRAWING

WEIGHT (g)	140	±	5
OVERFLOW (Fl Oz)	144	±	1.80
(cc)	4250.5	±	53
BOTTLES	45'	-	10,368
PER TRAILER	48'	-	11,232
	53'	-	12,096

DISCLAIMER

THIS INFORMATION IS PROVIDED AS A GENERAL GUIDE, INCLUDING DIMENSIONS. IT IS THE CUSTOMER'S RESPONSIBILITIES TO SELECT THE PROPER CONTAINER FOR PRODUCT AND APPLICATION COMPATIBILITY.

DISTRIBUTED BY:



REF NO.:

DWG30715

DESCRIPTION:

128 oz White HDPE F-Style, 38-400