

Ⓔ 38mm SP-400 SCREW FINISH
"M" STYLE THREAD
WITH 1-1/2 TURNS

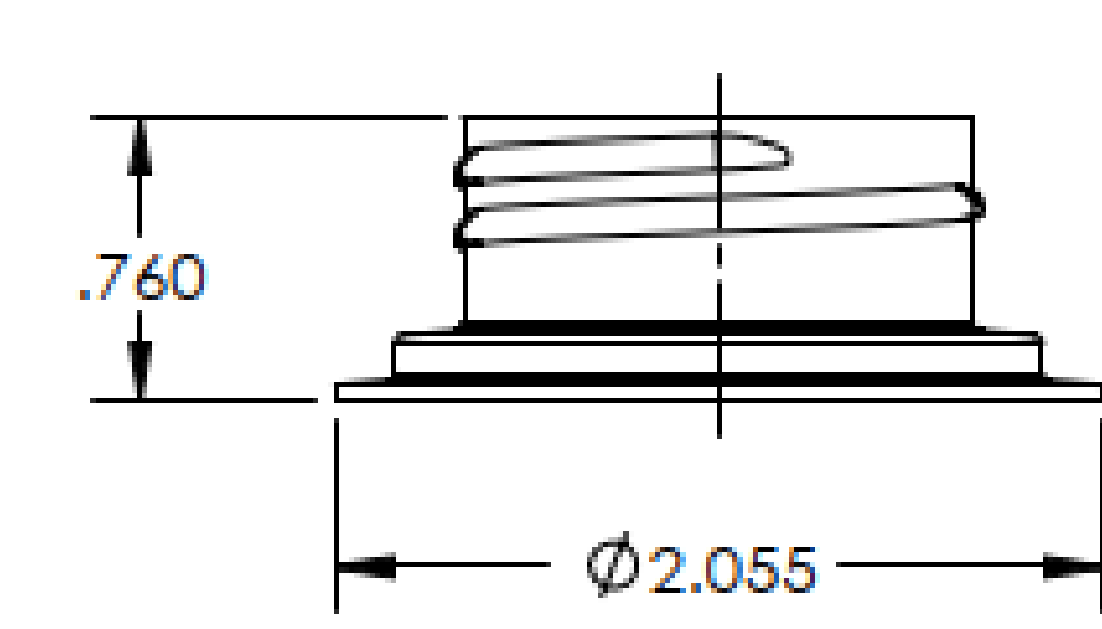

Ⓕ 38mm SP-400 SCREW FINISH
"M" STYLE THREAD
WITH 1-1/2 TURNS

BcYg
%7 cbHJbYFK Y[\h!! %0!%&\$ [fUa g
&EA UHYfU!! <8D9
'Ej YfZck 7 UdUWmk Jh 5 HYfbUH' 6ctca !!% (" 'cn'
"Cj YfZck 7 UdUWmk Jh GubXUfX 6ctca !!% + " 'cn'
(E: j 7 UdUWm!! %& "\$'cn'
)Etc YfUbwgl bYggGdYWZYX.
"J YfWU!! "\$, \$"
"c fncbU!! "\$, \$"
"J c' a YfWU!! %) '\$'cn'
*E6ctHYgfc VY 7 YWYX 5[YX k Jh (7 K UHY F
+E9gja UhX '6i [Y!! &)" '\$'cn'

DISCLAIMER

THIS INFORMATION IS PROVIDED AS A GENERAL GUIDE, INCLUDING DIMENSIONS. IT IS THE CUSTOMER'S RESPONSIBILITIES TO SELECT THE PROPER CONTAINER FOR PRODUCT AND APPLICATION COMPATIBILITY.

DISTRIBUTED BY:



REF NO.:

DWG30774

DESCRIPTION:

128 oz Natural HDPE Industrial Square, 38-400, 120 Gram