

See Spout & Orifice Data Below

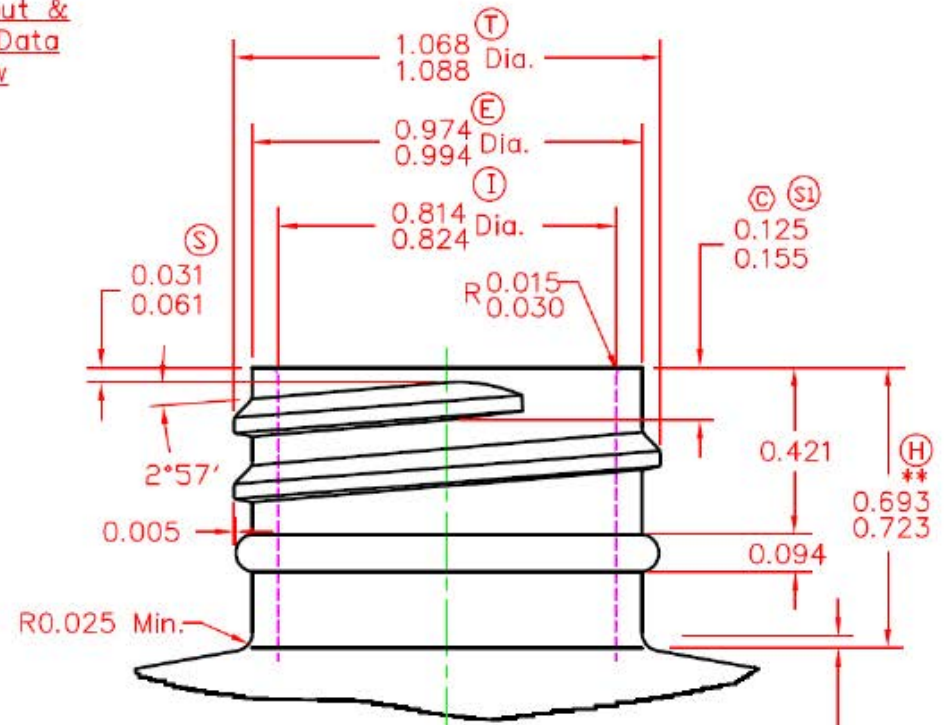

Per C.M.A. Standard
 "T" = 1.103/1.089 Dia.
 "E" = 1.009/0.995 Dia.

**0.016-0.062
 Skirt to Bottle
 Clearance Range
 Of Extreme
 Tolerances
 (Land seal only)

† Seal Type No. 1: Valve Seal (The most efficient provided bottle has proper "I" dimension)

‡ Seal Type No. 2: Land Seal ("I" dimension of bottle less critical than above)

Dimensions marked * are an average of two measurements taken 90° apart.

GENERAL TOLERANCE NOT SHOWN OTHERWISE: ± .008

BOTTLE NOTES:

- 1) Thread: 6 Pitch, Per S.P.I. Standard.
- 2) Diameters must be concentric within .015" T.I.R.
- 3) All Dimensions are in inches unless otherwise indicated.

DISCLAIMER

THIS INFORMATION IS PROVIDED AS A GENERAL GUIDE, INCLUDING DIMENSIONS. IT IS THE CUSTOMER'S RESPONSIBILITIES TO SELECT THE PROPER CONTAINER FOR PRODUCT AND APPLICATION COMPATIBILITY.

DISTRIBUTED BY:



REF NO.:

DESCRIPTION: