

6 THREADS PER INCH, .167 PITCH, 380° FULL DEPTH THREAD			
REFERENCE	TOLERANCE	DIMENSION	UNITS
E	±0.012 [0.31]	1.006 [25.60]	in [mm]
T	±0.012 [0.31]	1.100 [27.90]	in [mm]
H [Sealed]	REFERENCE	0.514 [13.06]	in [mm]
H [Inner]	±0.012 [0.31]	0.395 [10.00]	in [mm]
OD	±0.017 [0.43]	1.375 [34.93]	in [mm]
OAH	±0.017 [0.43]	0.677 [17.20]	in [mm]
PART WEIGHT	± 0.80	4.90	g

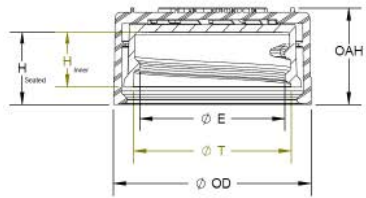

SECTION A-A



DETAIL RIBS
SCALE 8 : 1

(58) EQUISPACED RIBS

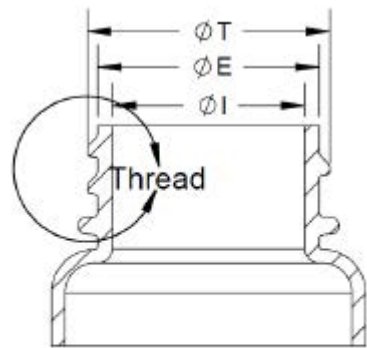
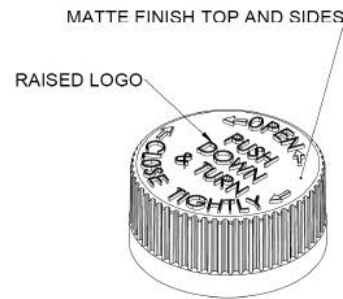

SECTION DW-DW
SCALE 5 : 4

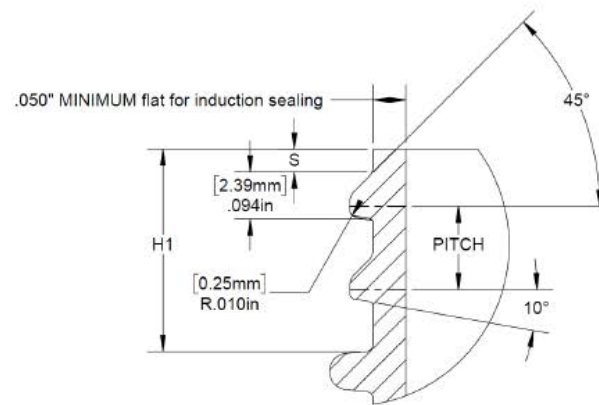
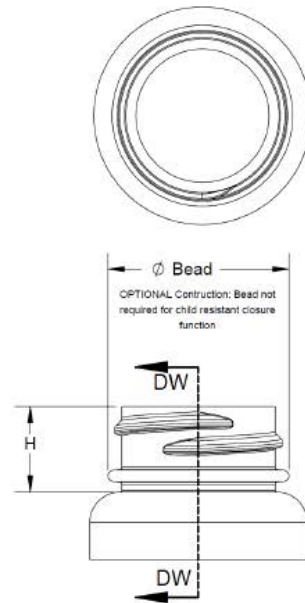

DETAIL Thread
SCALE 4 : 1

REFERENCE	TOLERANCE	UNITS	DIMENSION
E	± 0.010 [0.25]	in [mm]	0.984 [24.99]
T	± 0.010 [0.25]	in [mm]	1.078 [27.38]
I	MINIMUM	in [mm]	0.614 [15.60]
S	±0.015 [0.38]	in [mm]	0.046 [1.17]
H1	MINIMUM	in [mm]	0.550 [13.97]
H	MINIMUM	in [mm]	0.411 [10.44]
BEAD	MAXIMUM	in [mm]	1.130 [29.46]
TPI			6
PITCH		in [mm]	0.167 [4.24]

DISCLAIMER

THIS INFORMATION IS PROVIDED AS A GENERAL GUIDE, INCLUDING DIMENSIONS. IT IS THE CUSTOMER'S RESPONSIBILITIES TO SELECT THE PROPER CONTAINER FOR PRODUCT AND APPLICATION COMPATIBILITY.

DISTRIBUTED BY:



REF NO.:

DESCRIPTION: