

6 THREADS PER INCH .167 PITCH,
380° FULL DEPTH THREAD

	TOLERANCE	UNITS	
E	±0.008 [0.20]	in [mm]	1.986 [50.44]
T	±0.008 [0.20]	in [mm]	2.081 [52.86]
H_(Assm)	MINIMUM	in [mm]	0.472 [12.00]
H_(Inner)	±0.008 [0.20]	in [mm]	0.398 [10.11]
OD	±0.010 [0.25]	in [mm]	2.388 [60.66]
OAH	±0.012 [0.30]	in [mm]	0.690 [17.53]
Part Weight	±1.4	g	12.8

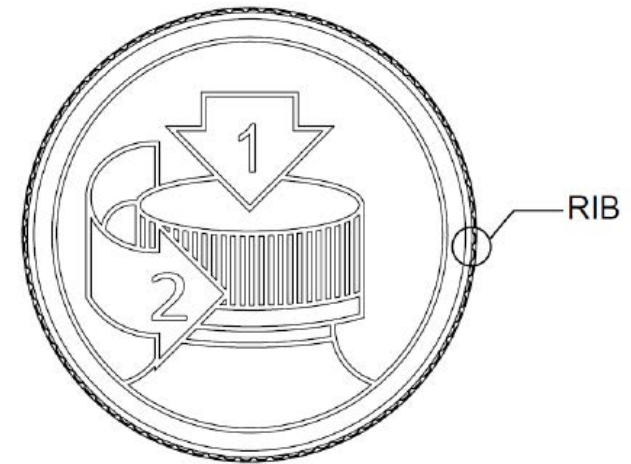

DETAIL F
SCALE 6
(88) EQUISPAC

Recommended Neck Finish

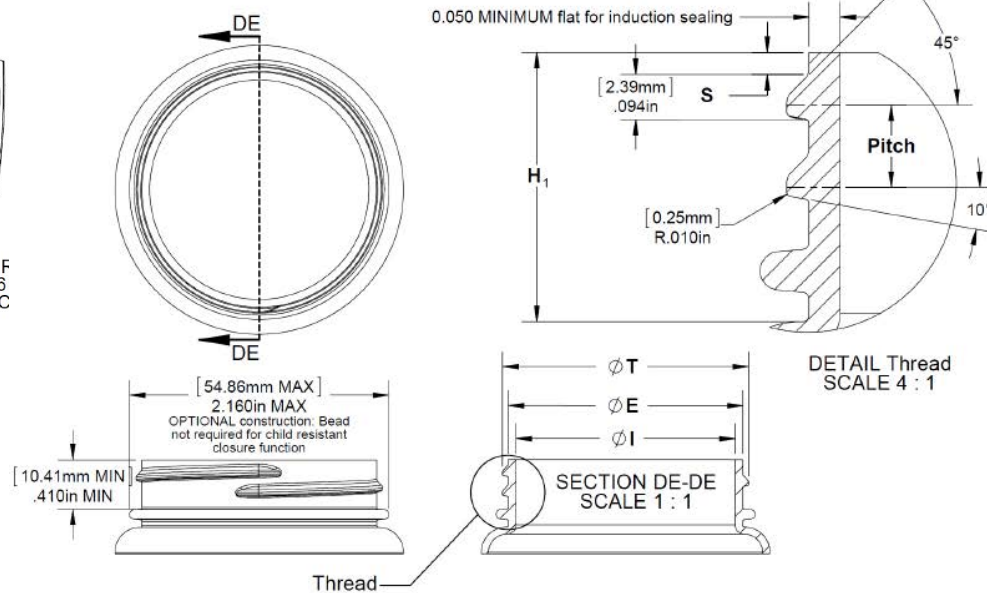

DETAIL Thread
SCALE 4 : 1

	TOLERANCE	UNITS	
E	±0.017 [0.43]	in [mm]	1.956 [49.68]
T	±0.017 [0.43]	in [mm]	2.050 [52.07]
I	Minimum	in [mm]	1.578 [51.64]
S	±0.015 [0.38]	in [mm]	0.046 [1.17]
H₁	±0.015 [0.38]	in [mm]	0.560 [14.22]
TPI			6
PITCH		in [mm]	0.167 [4.24]

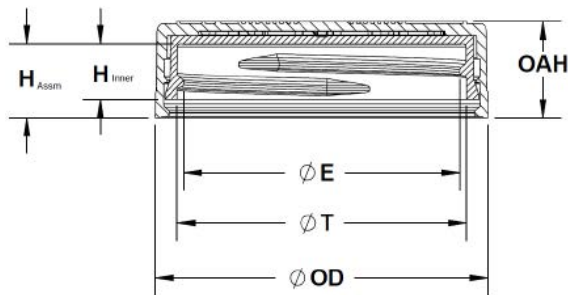

SECTION X-X
SCALE 1 : 1

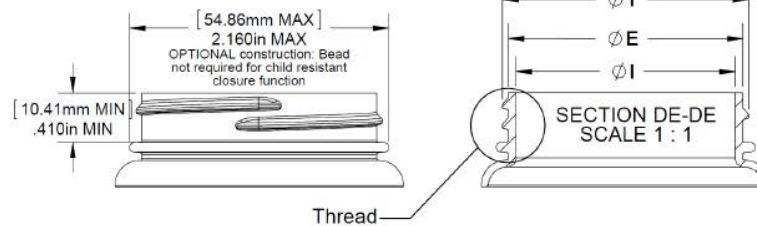

SECTION DE-DE
SCALE 1 : 1

DISCLAIMER

THIS INFORMATION IS PROVIDED AS A GENERAL GUIDE, INCLUDING DIMENSIONS. IT IS THE CUSTOMER'S RESPONSIBILITIES TO SELECT THE PROPER CONTAINER FOR PRODUCT AND APPLICATION COMPATIBILITY.

DISTRIBUTED BY:



REF NO.:

DESCRIPTION: