

TWO PIECE CAP
ASSEMBLED

6 THREADS PER INCH

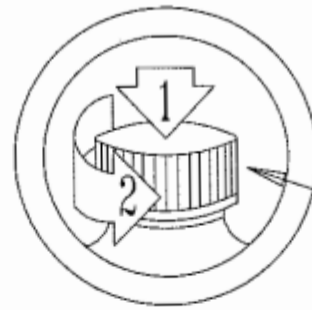

PICTORIAL DESIGN
.022 HIGH

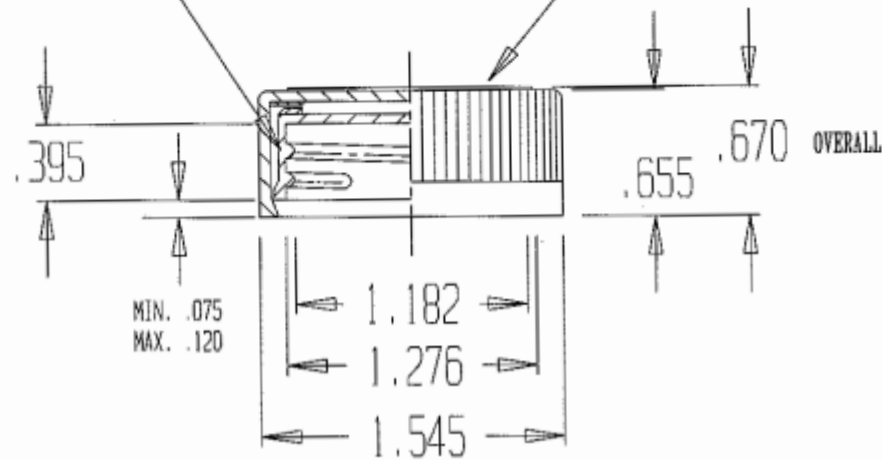

"T"	"E"	"H"	"A"	"B"
1.276	1.182	.395	1.545	.670
MATERIAL: POLYPROPYLENE				
WEIGHT: 6.2 GRAMS (+/- 1 gram)				

DISCLAIMER

THIS INFORMATION IS PROVIDED AS A GENERAL GUIDE, INCLUDING DIMENSIONS. IT IS THE CUSTOMER'S RESPONSIBILITIES TO SELECT THE PROPER CONTAINER FOR PRODUCT AND APPLICATION COMPATIBILITY.

DISTRIBUTED BY:



REF NO.:

DWG30811

DESCRIPTION:

33-400 White PP Child Resistant Cap with SG75 Printed Liner

Product	.020" Pulp SG-75M																				
Scope	Two piece white-lined pulp backed heat induction foil innerseal that will provide a tamper evident seal to PE containers.																				
Composition	<table border="1"> <thead> <tr> <th>Material</th> <th>Standard</th> <th>Metric</th> </tr> </thead> <tbody> <tr> <td>Pulp</td> <td>0.020"</td> <td>0.508mm</td> </tr> <tr> <td>Wax</td> <td>-</td> <td>-</td> </tr> <tr> <td>Foil</td> <td>0.001"</td> <td>0.025mm</td> </tr> <tr> <td>PET Film</td> <td>0.0005"</td> <td>0.013mm</td> </tr> <tr> <td>Heat Seal</td> <td>0.0015"</td> <td>0.038mm</td> </tr> </tbody> </table>	Material	Standard	Metric	Pulp	0.020"	0.508mm	Wax	-	-	Foil	0.001"	0.025mm	PET Film	0.0005"	0.013mm	Heat Seal	0.0015"	0.038mm		
Material	Standard	Metric																			
Pulp	0.020"	0.508mm																			
Wax	-	-																			
Foil	0.001"	0.025mm																			
PET Film	0.0005"	0.013mm																			
Heat Seal	0.0015"	0.038mm																			
FDA Status: 21 CFR 175.300	Recommended Storage and Handling: Refer to website																				
Drug Master File (DMF): 3782	EU / EP Reg.:																				
GTR Oxygen: Essentially Zero	MVTR: Essentially Zero																				
Sealing to glass containers: Pipeline can not guarantee the performance or seal integrity of this materials when applied to any glass (treated or untreated) container. We suggest you contact your glass supplier for recommendations on glass treatments that may or may not improve performance or seal integrity.																					
Print Location (if any): On foil layer																					

<p align="center">DISCLAIMER</p> <p>THIS INFORMATION IS PROVIDED AS A GENERAL GUIDE, INCLUDING DIMENSIONS. IT IS THE CUSTOMER'S RESPONSIBILITIES TO SELECT THE PROPER CONTAINER FOR PRODUCT AND APPLICATION COMPATIBILITY.</p>	<p>DISTRIBUTED BY: </p>	<p>REF NO.: DWG30811</p>
	<p>DESCRIPTION: 33-400 White PP Child Resistant Cap with SG75 Printed Liner</p>	