

NOTE: THE CAP IS SHOWN WITHOUT A LINER

©

LINER #	LINER DESCRIPTION
502	F217 FOAM
565	1 MIL HEAT SEAL
655	PS113 PRESSURE SENSITIVE W/FOAM BACKING

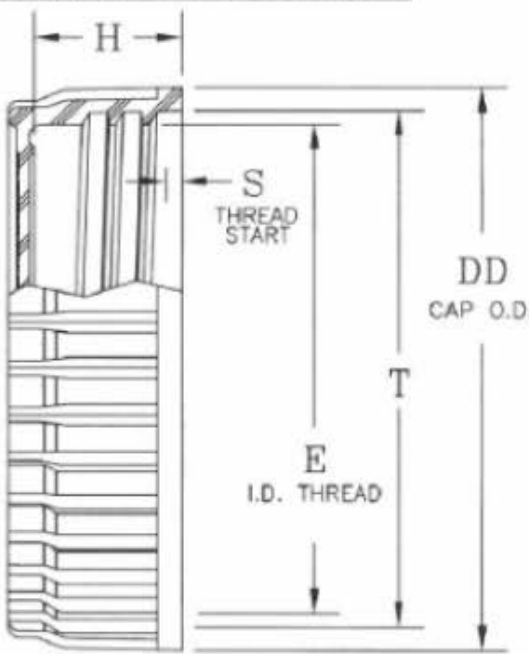
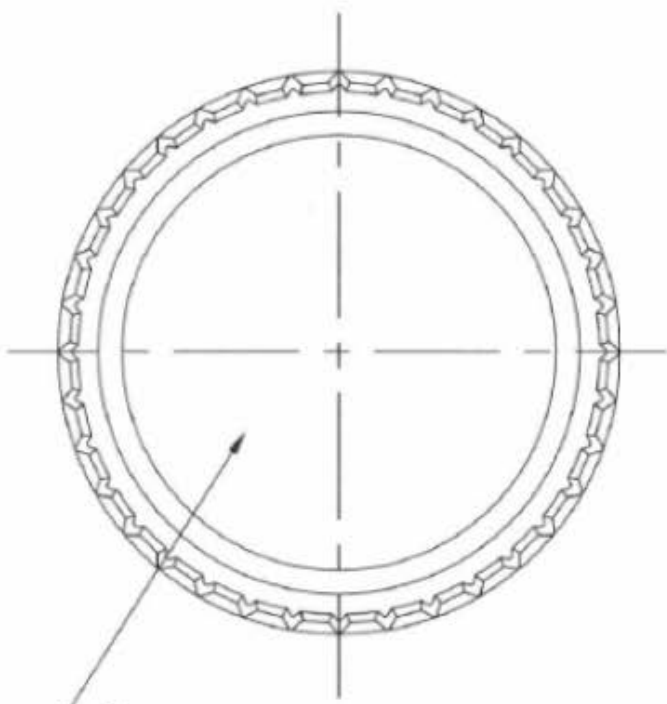
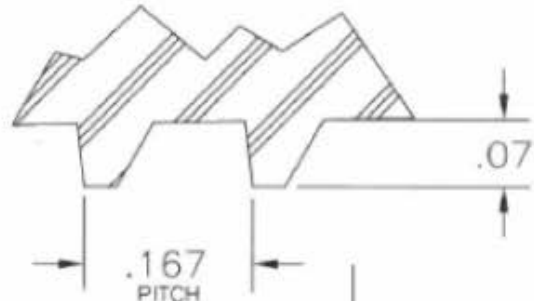

ⓑ OPTION: PRINTING OR EMBOSSING TO CUSTOMER REQUIREMENTS

ITEM	DD	E	H	S	T
SPEC.	$\phi 2.757 \pm .012$	$\phi 2.389 \pm .011$	$.725 \pm .008$	$.070 \pm .015$	$\phi 2.541 \pm .013$

NOTE:
THE MATERIALS USED MEETS FDA REQUIREMENTS DEPENDING ON COLOR

<p>DISCLAIMER</p> <p>THIS INFORMATION IS PROVIDED AS A GENERAL GUIDE, INCLUDING DIMENSIONS. IT IS THE CUSTOMER'S RESPONSIBILITIES TO SELECT THE PROPER CONTAINER FOR PRODUCT AND APPLICATION COMPATIBILITY.</p>	<p>DISTRIBUTED BY: Pipeline Packaging</p>	<p>REF NO.: DWG20568</p>
	<p>DESCRIPTION: 63 mm PP Screw Cap</p>	