

NOTES:

- 1) EFFECTIVE "H" IS ESTABLISHED BY SUBTRACTING GASKET THICKNESS FROM OVERALL "H"
- 2) MATERIALS USED MEET FDA REQUIREMENTS
- 3) 6TPI, .167 PITCH

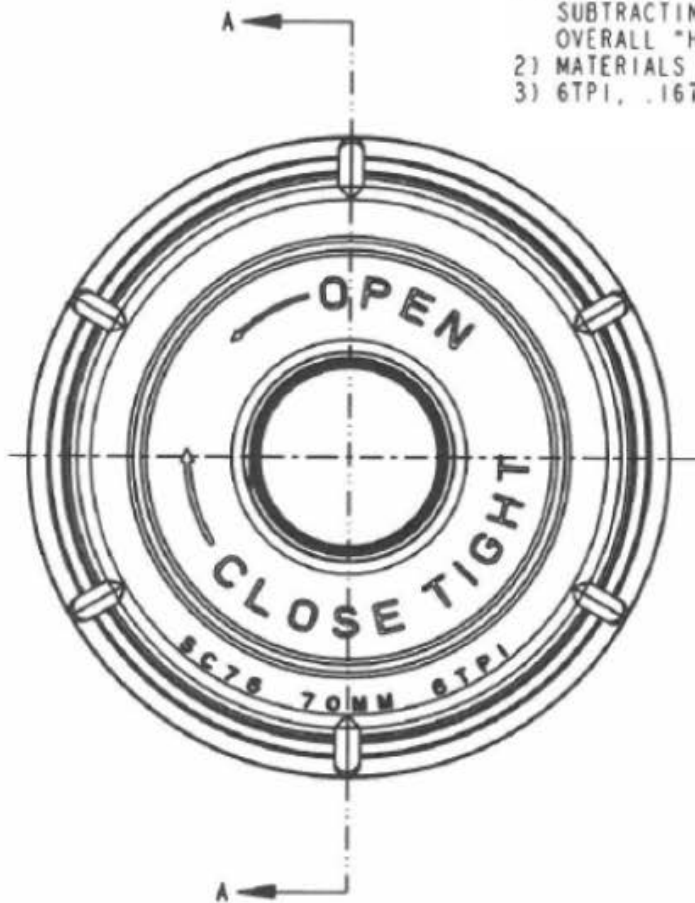

3/4 - 14 THREAD

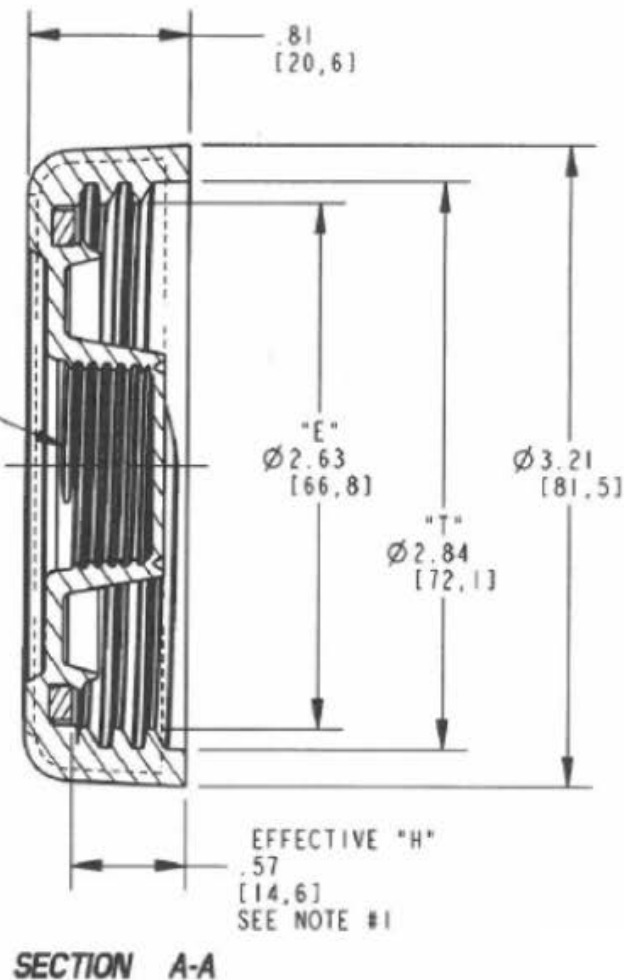

DISCLAIMER

THIS INFORMATION IS PROVIDED AS A GENERAL GUIDE, INCLUDING DIMENSIONS. IT IS THE CUSTOMER'S RESPONSIBILITIES TO SELECT THE PROPER CONTAINER FOR PRODUCT AND APPLICATION COMPATIBILITY.

DISTRIBUTED BY:



REF NO.:

DESCRIPTION: